



2H25 YETI

ESTE DOCUMENTO ES CONFIDENCIAL

TE RECORDAMOS QUE ESTA INFORMACIÓN NO ES PÚBLICA, ES CONFIDENCIAL Y POR LO TANTO, SU DIFUSIÓN NO ESTÁ PERMITIDA NI TAMPOCO, HACER NINGÚN TIPO DE PUBLICACIÓN DE LA MISMA. ESTA INFORMACIÓN DEBE PERMANECER EN PRIVADO.

QUALQUIER DIVULGACIÓN DE ESTE DOCUMENTO INCURRIRIA EN UNA VIOLACIÓN D CONTRATO ENTRE MARCA Y CLIENTE. POR TANTO, SI NO SE RESPETA LA CONFIDENCIALIDAD, PODRÍA RESULTAR EN LA FINALIZACIÓN DE LA RELACIÓN COMERCIAL. ADEMÁS, LA MARCA PODRÍA HACER USO DE TODAS LAS ACCIONES LEGALES PERTINENTES QUE CONSIDERARA OPORTUNAS.

USA ESTE DOCUMENTO EN ESTRICTA CONFIDENCIALIDAD Y DE ESTA MANERA PROTEGEREMOS LA MARCA, CONSERVANDO EL SECRETO DE SUS NUEVOS COLORES Y PRODUCTOS HASTA EL DÍA DE SU LANZAMIENTO.



YETI

STORY

YETI founders, brothers Roy and Ryan Seiders, set out to build a cooler without compromise. Since 2006, we've built even more products that stand up to the hazards of the wild so you can stay out longer, travel farther and live harder. No matter where the wild takes you, there's a YETI ready to tackle your next adventure head on.

A person wearing a red jacket and a red hat is seen from behind, carrying a large, dark-colored pack on a snowy mountain slope. The person is walking up the slope, and the background shows a vast, snow-covered landscape under a clear sky. The overall scene is in a cool, blue-toned color palette.

PRODUCTS
WITHOUT
COMPROMISE

YETI

**MOVING
COOKING
GATHERING**



2H25 KEY PRIORITIES

AMPLIFY FOOD



WIN DRINKWARE



DRIVE AWARENESS
AND ADOPTION



2H25 THEMES



MOVING

Led by Bag & Food Transport



COOKING

Led by Food, Coolers, Outdoor Living



GATHERING

Led by Food & Bev, Coolers

KNOWING

KEY AREAS OF GROWTH

BAGS

TRAVEL VESSELS

FOOD CONTAINERS

SOFT COOLERS

ROADIES

GO BOX



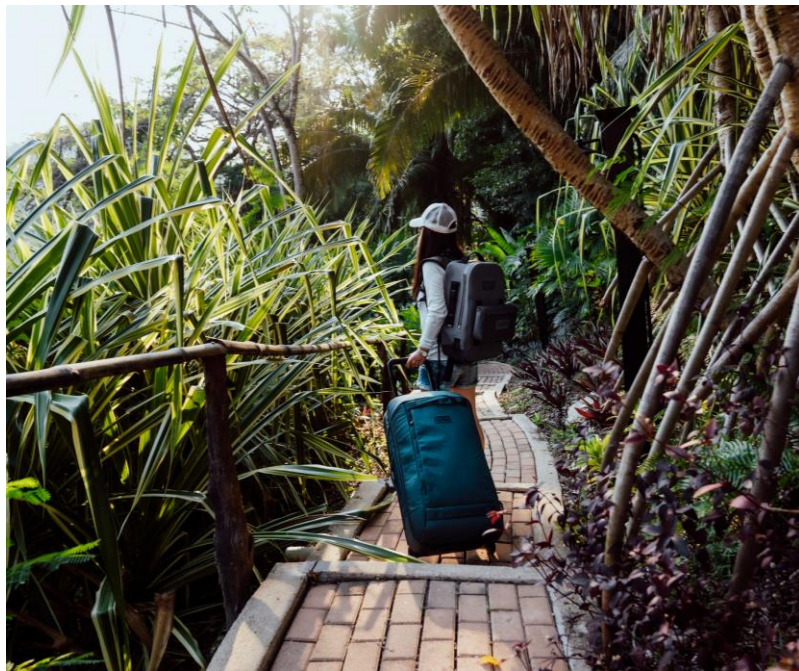

'MOVING' THEME
NEW PRODUCTS

EMERGENCY AGENTS





EXTEND USE CASES

EXTEND OPTION

OFFERING ONE MORE SIZE

YETI LOADOUT® GOBOX MICRO

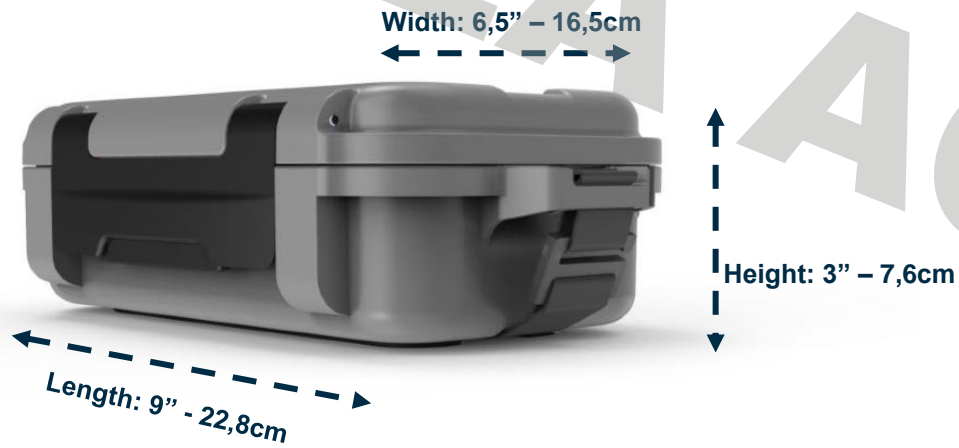

YETI LOADOUT® GOBOX MICRO

CONSUMER NEED

Supreme safety for risk takers who don't take risks when it comes to the vitals. The GoBox Micro keeps safe the things you can't live without.

CONSUMER TARGET

Those who take on knocks, rocks, drops, and anything wet.

THE DOESN'T FAIL-SAFE

HANDLE WITHOUT A CARE

Ultradurable, weather-resistant hard exterior with Locking Ports and Tiedown Features.

RIGHT SIZED

Designed to hand-carry or stow; fits most phones.

THOUGHTFUL INTERIOR DESIGN

Removable Pack Attic for securing skinnier valuables like credit cards, cash, IDs, park passes, permits, and passports



INLINE



YETI[®] LOADOUT[®] GOBOX[®] FAMILY



YETI[®]

COMPATIBLE ACCESSORIES



Panga[®] 28L
Waterproof Backpack



Lowlands[®] Blanket



Camino[®] 35 Carryall Tote Bag



Loadout[®] 5-Gallon Bucket

LOADOUT GOBOX MICRO

PRODUCT OVERVIEW AND GO-TO-MARKET



D2C LAUNCH

10/7



WHOLESALE LAUNCH

10/7

INLINE COLORS

TAN

CHARCOAL

KING CRAB ORANGE

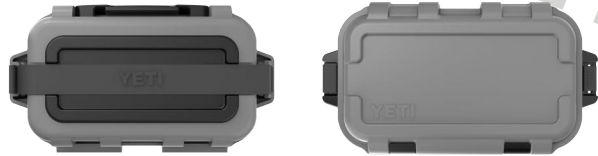

70€/£65

REASONS TO BELIEVE

Durable:

Bull simple design, bull tough material casing, iron-clad latching system

Versatile:

Able to securely hold smaller essentials and attach to a wide variety of things

Organization:

Keep contents safe by keeping them appropriately separated

Protective:

Waterproof and dustproof to an IP67 Rating



HEAD TO HEAD COMPARISON



SIDEKICK DRY 3L
KEEP VALUABLE SAFE
SOFT BAG
COMPATIBLE WITH BAGS
3 / 10
100% DRY
2 COMPARTMENTS
1L/3L/6L
IPX7

NAME
USAGE
TYPE
COMPATIBILITY
PROTECTION
DRY
INNER POCKET
OTHER SIZES
NORMS

GO BOX MICRO
KEEP VALUABLE SAFE
HARD CASE
CAN BE LATCHED
10 / 10
100% DRY
3 COMPARTMENTS WITH TRAY
MICRO/15/30/60
IP65 AND IP67

WHAT IS IP65 AND 67 MEAN?



Solids - 1st Digit

- 0** Not protected
- 1** Protection from objects >50mm (like a hand)
- 2** Protection from objects >12mm (like a finger)
- 3** Protection from objects >2.5mm (like a cable)
- 4** Protection from objects >1.0mm (like a nail or wire)
- 5** Dust protected - resistant to incidental dust
- 6** Dust tight - no ingress of dust

Liquids - 2nd Digit

- 0** Not protected
- 1** Protection from vertically dripping water
- 2** Protection from dripping water when tilted up to 15°
- 3** Protection from spraying water up to 60° from its normal position
- 4** Protection from splashing water from any direction
- 5** Protection from water jets from any direction
- 6** Water resistant against powerful jets
- 7** Protection from immersion (up to 1M) for a limited time
- 8** Protection from continuous submersion (beyond 1M)
- 9** Protection from close-range high pressure water jets

Ingress Protection

IP65
Solids Liquids



USE CASES: CORE PURSUITS



PURSUIT	USE CASE
MOUNTAINS SNOW	Protection from snow, moisture, and impact. It can securely store items like a smartphone, ski passes, or a GoPro, shielding them from snow, ice, and accidental drops.
MOUNTAIN HIKE/CLIMB	Waterproof and shockproof storage. It can carry and protect valuables like a GPS device, phone, or a portable charger from sudden weather changes, dust, and falls during hikes.
CAMPING	Safeguarding essentials like matches, snacks, or small electronics from rain, dirt, and animals. Its durability ensures that your most important items stay dry and intact.
COASTAL	Waterproofing and floating ability. It is perfect for protecting phones, wallets, and small tools from saltwater, splashes, and accidental drops into the water (watertight and floats).
CULINARY	Keeping Fire Starters Dry, Storing Utensils or Tools: You can store small grilling tools like a thermometer, tongs, or bottle openers, protecting them from grime or damage.
HUNTING	Dustproof and crushproof gear storage. Hunters can use the R40 to store optics, small electronics, or snacks, keeping them safe from dirt, mud, and rough handling in the wilderness.
FISHING	Waterproof and corrosion resistance. It can store tackle, keys, or phones, ensuring they stay dry even in a wet or humid environment, while also preventing rust or damage from saltwater.
EQUESTRIAN	Secure storage against dust, dirt, and shocks. Riders can use it to keep personal items like phones, small medical supplies, or snacks protected while riding in muddy or dusty environments or during long rides.

KEY COMPETITOR

R40 RUCK CASE FROM PELI



Exterior: 250 x 155 x 73 mm

£62.64/ 87EUR

YETI: 228 x 165 x 76mm

£65/ 70EUR



CARGO – LOAD OUT GOBOX CASES YETI E-commerce exclusive
NEW New 2H25 products

LOAD OUT GOBOX 60L



CHARCOAL



TAN



KING CRAB ORANGE



BLACK FOREST GREEN

NEW

LOADOUT GOBOX 30L



CHARCOAL



TAN



KING CRAB ORANGE



BLACK FOREST GREEN

NEW



WETLANDS CAMO

LOADOUT GOBOX 15L



CHARCOAL



TAN



KING CRAB ORANGE



BLACK FOREST GREEN

NEW

LOADOUT GOBOX MICRO 1L



CHARCOAL



TAN



KING CRAB ORANGE

NEW

NEW

NEW

CARGO – LOAD OUT GOBOX BUCKETS

LOAD OUT GOBOX 40L BUCKET



CHARCOAL



TAN



SEAFOAM



BLACK FOREST GREEN



WETLANDS CAMO

NEW

LOAD OUT GOBOX 40L BUCKET Accessories



LOADOUT® BUCKET UTILITY GEAR BELT



LOADOUT® BUCKET CADDY



SWIVEL SEAT



TRAVEL BOTTLE

EMILIA AGENTTS

HOT SHOT 2.0

- New Name: **TRAVEL BOTTLE**
 - Allowing consumer to envision Hot and Cold in the vessels
- Prices alignment:
 - Hot Shot 12oz: 33EUR / 28GBP
 - Hot Shot 16oz: 37EUR / 32GBP
 - Hot Shot 20oz: 40EUR / 35GBP
- Launch intro date:
 - **7/1/25**



RAMBLER TRAVEL BOTTLE

TAPERED SILHOUETTE - LOWER PROFILE



TRAVEL BOTTLE PRODUCT DESIGN

Vessels: 12oz, 16oz, and 20oz
Designed to accommodate cup holders



Recessed pocket to help avoid nose collision and reduce head tilt while driving. Channeled flow path helps direct liquid.

3-part system is compact and low profile.

1. Place puck inside while aligning the grooves.



2. Magnetic puck travels upwards and rotates as the Upper is unscrewed to drink.



3. Magnetic puck collides with the lower preventing it from further unscrewing.

Visual and Tactile methods used to indicate open and closed states

Puck is magnetically held in place. Remove Mag Puck to disassemble and clean.



BAGS

YETI BAGS STRATEGY



PRIORITIZED COMMUNITIES WITHIN BAGS

MOUNTAIN

DAYPACKS/TRAIL PACKS



HUNT

WATERFOWL/WESTERN



FISH

RIVER



SURF

GEAR BAGS



WELLNESS

RUN/GOLF/GYM



-----|----- Cross-Community Pursuits -----|-----

EVERYDAY

TRAVEL

~~BACKROAD~~

CAYO

CAYO is the Spanish for "KEY, ISLET"
Example: Key West, Florida is Cayo Hueso is Spanish

YETI

BAGS OVERVIEW

TRAVEL

OVERNIGHTS TO OVERHEADS



CROSSROADS
PACKING CUBES



EVERYDAY

COMMUTERS AND DAYTRIPPERS



CAMINO
RANCHERO **NEW!**



PROTECTION

DOWNPOURS & DEEP WADING



SIDEKICK
PANGA
CAYO **NEW!**



BAGS | BACKPACKS PORTFOLIO

TRAVEL

OVERNIGHTS TO OVERHEADS

EVERYDAY

COMMUTERS & DAY TRIPPERS

PROTECTION

DOWNPOURS & DEEP WADING

CROSSROADS



*NO COMPROMISES
ORGANIZATION BUILT FOR
EVERYDAY OR A WEEKEND
AWAY.*

Built for Travel.

RANCHERO



*ACCESSIBILITY THROUGH
MULTI-FACETED OPENING
OPTIONS, AND COMFORT
FOR ALL.*

Built for Everyday.

CAYO



*DURABLE, WEATHER-
RESISTANT & AGILE FOR
DAILY USE.*

Built for the Enthusiast.

PANGA



*FULLY SUBMERSIBLE,
ADVENTURE-GRADE TO
KEEP GEAR DRY.*

Built for the Water.

BAGS | BACKPACKS PORTFOLIO

TRAVEL

OVERNIGHTS TO OVERHEADS

EVERYDAY

COMMUTERS & DAY TRIPPERS

PROTECTION

DOWNPOURS & DEEP WADING

CROSSROADS



Your no-compromises backpack for everyday chores.

Who/Why:

For the everyday commuter, traveler or professional who wants a premium, durable and comfortable bag with lots of storage and organization.

RANCHERO



Made for everyday versatile use, inspired by urban lifestyle; rugged mountain toughness.

Who/Why:

For the commuter or professional that is always on the move, transitioning between different environments who need a premium durable, and comfortable that can act as their daily basecamp.

CAYO



Meeting the demands of outdoor adventurers who require durability, weather protection and ultimate agility.

Who/Why:

For the outdoor adventurer who wants one bag that performs in all aspects of life – keeps their outdoor gear safe from the elements on the weekend and their laptop protected on the weekdays. This bag is tough but still delivers on premium aesthetic, durability and comfort.

PANGA



Our fully submersible, adventure-grade bags keep your gear bone-dry on the river, at sea, or wherever you go.

Who/Why:

For the outdoor adventurer who needs pinnacle protection from water and weather in their pursuit of choice. Can run the spectrum from everyday fisherman to extreme.

BAGS | BACKPACKS PORTFOLIO

TRAVEL

OVERNIGHTS TO OVERHEADS

EVERYDAY

COMMUTERS & DAY TRIPPERS

PROTECTION

DOWNPOURS & DEEP WADING

CROSSROADS



Travel, Everyday

22L | 27L | 35L



Black/Olive

Weather Resistant

YKK RCPU

Stitched

RANCHERO



Urban Active, Everyday

22L | 27L



Black/Taupe/Olive

Weather Resistant

RipZip YKK RCPU

Stitched

CAYO



Outdoor Adventure, Surf, Skate, Bike,
Everyday, Commute

15L | 25L | 35L



Black/Olive

Weather Resistant ++

YKK Aquaguard

Welded

PANGA



Fish, Boat, Hunt, Camp, Adventure Travel

28L



Storm Grey/Tan/Black

Waterproof Submersible

YKK Aquaseal;
100% Waterproof

Welded

BAGS | A YETI ECOSYSTEM

A FOOD JAR OR FOOD CONTAINER TO BRING SNACKS WITH YOU AND KEEP YOUR BAG CLEAN



LEAKPROOF DRINKWARE SOLUTIONS ON-THE-GO



A SIDEKICK DRY OR A GO BOX MICRO TO PROTECT ALL YOUR VALUABLE FROM THE ELEMENTS



RANCHERO
CROSSROADS



HOPPER M

CAYO

PANGA

AN INSULATED DAYTRIP TO TRANSFORM THE BAG INTO A GREAT SOFT COOLER



A RAMBLER SLING TO EASE ACCESS AND STAY HYDRATED ON YOUR NEXT ADVENTURE



PACKING CUBES TO STORE, PACK AND KEEP THINGS IN PLACE



PRODUCT OVERVIEW

Quick access secure zip pocket.



Easy access zippered hydration storage pockets. (x2 symmetrical pockets on 25L & 35L, x1 pocket on 15L)

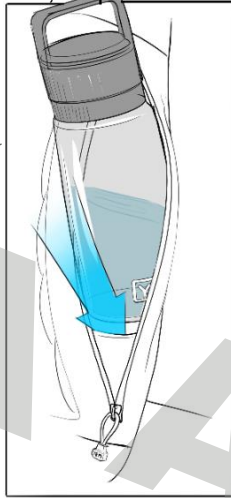

Top & side grab handles



Removable waist strap for added support & comfort.

Internal organization.

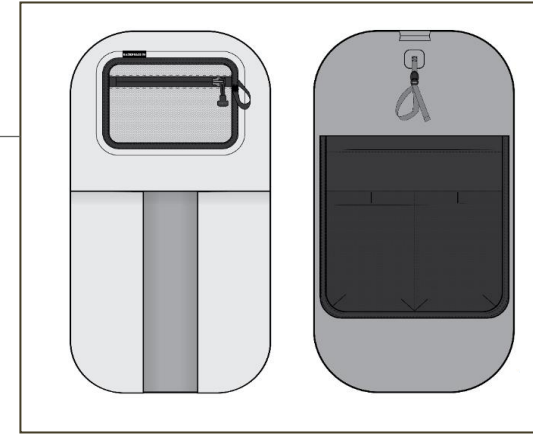

On face: Secure stretch mesh pocket. On back: Water hydration compatible with hanger & pass-thru. Hydration reservoir compartment duals as laptop pocket. Two open stretch pockets.

Ergonomic & breathable back panel.

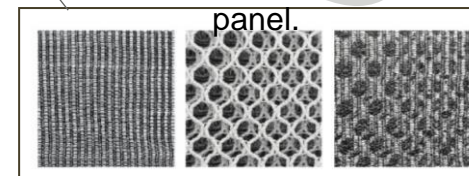

YETI[®] RANCHERO BACKPACK

CONSUMER NEED

For someone always on the move, transitioning between different environments, the ability to seamlessly access their stuff without slowing down is crucial.

CONSUMER TARGET

Trailblazers whose bag is their everyday basecamp.

OPENS WIDE IN WIDE OPEN SPACES

GRIP IT AND RIP IT

Pull-to-open RipZip™ technology for rapid access to everything inside.

ALL-DAY UTILITY

Laptop and tablet sleeves for days off the trail.

ULTRA DURABLE

TuffSkin™ nylon exterior is water and abrasion-resistant

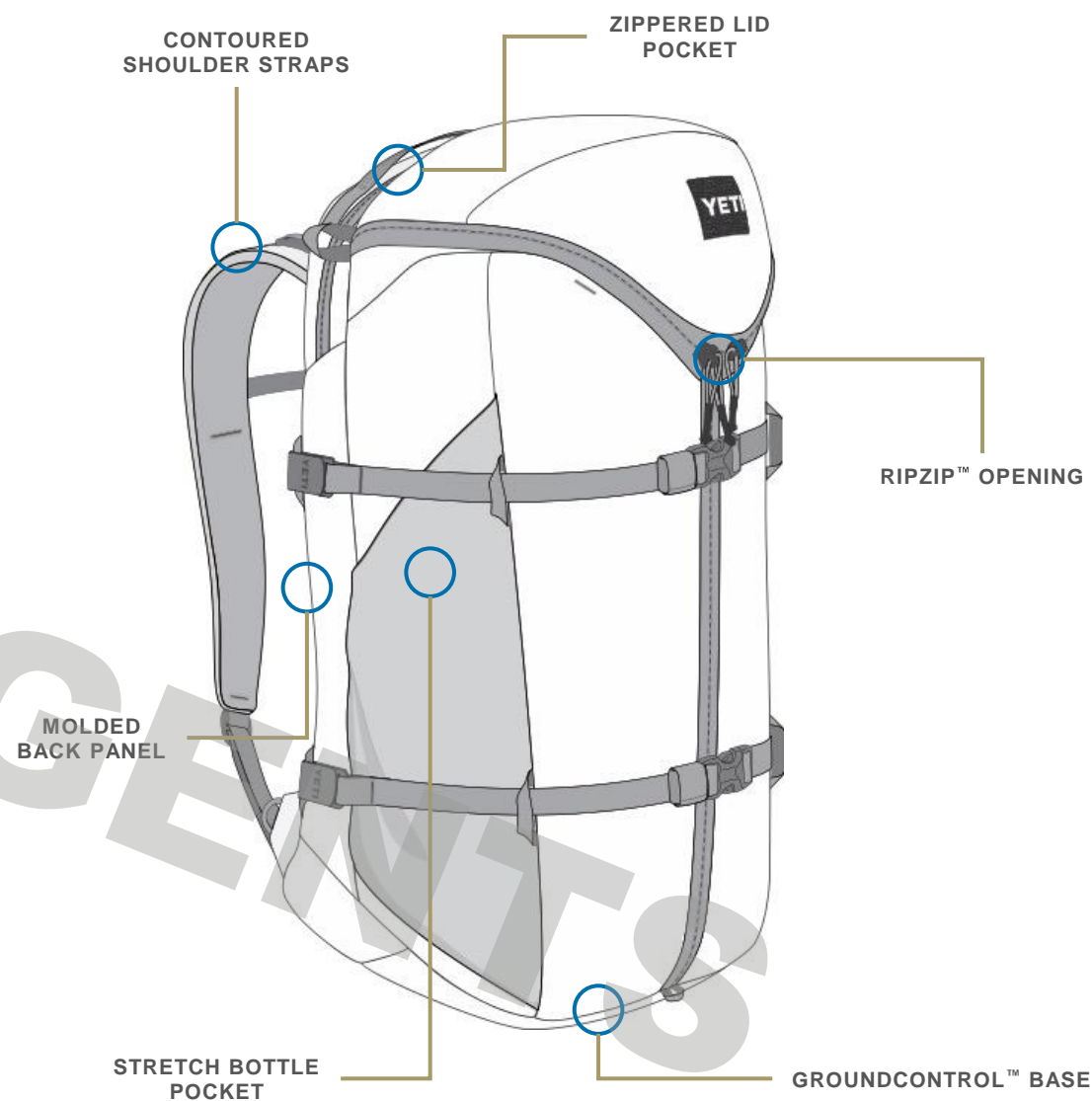

INLINE



YETI[®] RANCHERO BACKPACK

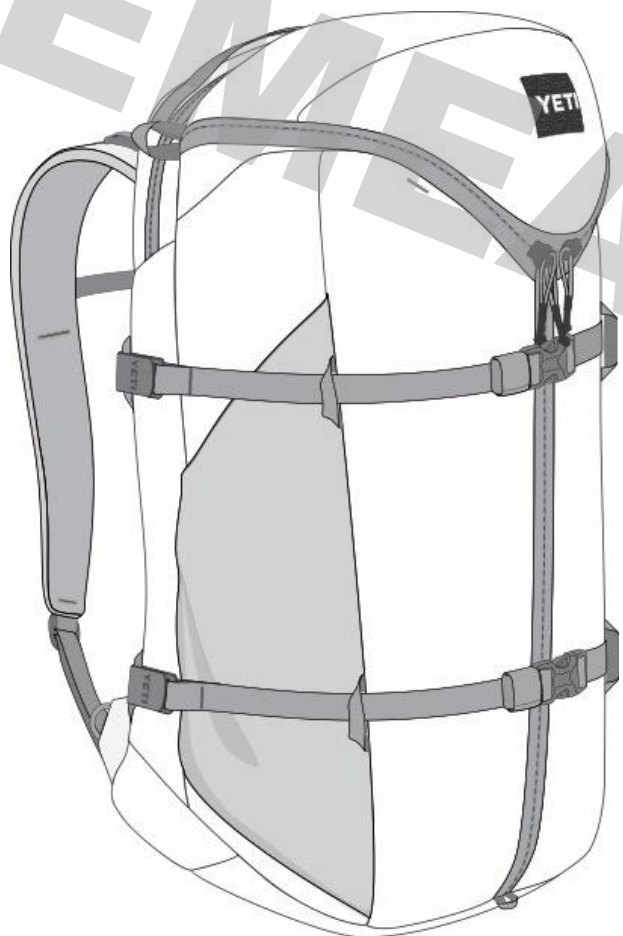

COMPATIBLE ACCESSORIES



Rambler[®] Drinkware
(Up to 36 oz)



YETI[®] Collectors' Patch



Daytrip[™] 3L Lunch Box

CROSSROADS

“RANCHERO”

CAYO

PANGA

HOPPER



Use Case	Travel, Everyday	Urban Active, Everyday	Outdoor Adventure, Surf, Skate, Bike, Everyday, Commute	Fish, Boat, Hunt, Camp, Adventure Travel	Keep items cold: Fish, Surf, Beach, Hike
Capacity	22L 27L 35L	22L 27L	15L 25L 35L	28L	12L 20L
Weather protection	Weather Resistant	Weather Resistant	Weather Resistant	Waterproof Submersible	Weather Resistant
Exterior Fabric	TuffSkin/700D Cordura	TuffSkin/700D Cordura	TPU coated Nylon	TPU coated Nylon	TPU coated Nylon
Closure	YKK RCPU	RipZip YKK RCPU	YKK Aquaguard	YKK Aquaseal; 100% Waterproof	Magshield Access
Construction	Stitched	Stitched	Welded	Welded	Welded
Built-in Hydration Storage	✓	✓	✓		
Water Reservoir compatible			✓		
Internal Organization	✓	✓	✓	✓	
Laptop Sleeve	✓	✓			
Exterior Access Pocket	✓	✓	✓		Kangaroo pocket. M12 only.
Removable Sternum strap	✓	✓	✓	✓	✓
Removable Waist Strap			✓	✓	Compatible; Not included
Hitch Point Grid/SideKick Compatible			✓	✓	✓
Insulated					✓

BAGS SELLING 101

Product

#1 Rule - Make sure the product looks its best!

- Crossroads & Ranchero (nylon fabric product): bag should always be stuffed so that it appears filled out; can use paper, pillow, etc.
- Panga & Cayo (TPU fabric product): no need to add stuffing to the bag, but could kit out to show use case. Include water reservoir within Cayo to show hydration optionality and pass-thru at the back of the bag.
- Tie up & loop back any loose straps.
- Backpack strap adjusters - fold back and loop cleanly.
- Sternum & Waist straps should be packed inside the bag, unless showing specific purpose of straps within a presentation.
- Compression straps
 - Crossroads - attach compression straps across the front exterior. Ensure straps are tight and secure with no loose straps.
 - Ranchero - compression straps should be packed inside bag in order to allow user to fully experience the Rip Zip feature that sets this bag apart.

Presentation

- Begin with reason for being, consumer insight and positioning within the YETI Bags portfolio
- When presenting a backpack, you always start with the back side first.
 - First, speak to reverse / back panel of bag speaking to product details and comfort.
 - Second, speak to front of the bag.
 - Finally, end with talking about interior and organization.

BAGS GLOSSARY OF TERMS

Product Details

- **Aquaseal Zipper** : Made by YKK, 100% waterproof zipper used on Panga (and Flip Soft Coolers)
- **Aquaguard Zipper**: Made by YKK, weatherproof zipper used on Backroads
- **Backtack**: construction stitch to reinforce seams for durability
- **Body Panel**: effectively the part of the bag that interacts with your back
- **Compression straps**: straps at front exterior of the bag that can be used to compress the volume of the bag or to attach bulky gear to the exterior of the bag.
- **DU Foam**: Densified Urethane – best in class comfort and longevity (i.e. doesn't compress over time). Used in Shoulder Pads.
- **Hitchpoint grid**: molle webbing on the front of bags (Panga, Backroads) that allow for attachment of accessories like SKD, Rambler Bottle Sling, Bottle opener, etc.
- **Liter** – Most common measurement of a bags capacity and standardized by the ASTM (American Society for Testing and Materials). Alternative is cubic inches, which has a ratio of 60:1
- **Matrix Foam**: hard and dense, good for structure , i.e. bottoms
- **Ribboning**: thin material used to cover seams on the inside of a bag – also for durability and aesthetic. This also houses the 6MM cord used for structural integrity
- **Ripstop**: nylon weave with a thicker thread every ¼" to stop tearing
- **Sternum strap**: strap that attach to backpack shoulder straps at chest height that provide support around upper back.
- **TPU**: Thermoplastic Polyurethane - coating used on Nylon to increase durability, tensile strength and water repellency without sacrificing flexibility.
- **Waist strap**: strap that attaches to backpack shoulder straps at waist height to provide support and distribute bag's weight more evenly across your body
- **Welded Seams**: seams that are bonded together.
- **Zipper Pulls**: the cord on a zipper slider

Performance

- **Water / Weather Resistant**: protects contents inside from brief periods of heavy rain/snow.
- **Waterproof**: allows zero ingress of water.
- **Submersible**: No water will get in when properly closed. When zippered the contents inside the bag are protected against water immersion for 30min at a depth of 1 meter.



COOKING

KEY AREAS OF GROWTH

CONTAINERS

COOLERS

FOOD JARS

YETI



'COOKING' THEME
NEW PRODUCTS





FOOD STORAGE

Continue to promote internal organization of coolers, as well as bring versatility, color, and organization inside YETI Food Storage.



RAMBLER FOOD JARS

YETI has mastered keeping food cold and now it's time we flex our ability to keep food hot.



8oz | 1 Cup

16oz | 2 Cup

24oz | 3 Cup

40oz | 5 Cup

RAMBLER FOOD JARS

PRODUCT DETAILS

Collection of four sizes to address consumer capacity needs.

Portfolio compatibility across Soft Coolers and Bags.

Larger sizes include bottom hand pocket for controlled grip for direct consumption

Weight of the lids:
Small 155g
Large: 317g

Stacking by Lid Size with Lids Installed

Lid Insulation to ensure contents stay hot or cold for as longer

Molded EPS foam insert
Similar to triple haul cap, jug lid, and hotshot



RAMBLER FOOD JARS

PRODUCT DETAILS

Closed



Quarter Turn for Venting no extra steps needed, seamless experience



Removal of Lid



Pull apart two-piece lid construction held together by magnets, allows for thorough cleaning. No special tools or inaccessible food traps.



RAMBLER FOOD JARS

PRODUCT OVERVIEW AND GO-TO-MARKET



D2C LAUNCH

4/29 (27/ 40 OZ 6/17)



WHOLESALE LAUNCH

4/29 (24/ 40 OZ 6/17)



8 oz 35€/£30 16 oz 45€/£40 24 oz 55€/£50 40 oz 65€/£60

INLINE COLORS

 WHITE

 NAVY

 BLACK

 STAINLESS

 RESCUE-RED

 TROPICAL-PINK



REASONS TO BELIEVE

Design:

Extension of YETI's elevated design language and DuraCoat compatible.
Comfort to eat directly out of the containers with utensils.
Easy to open, close, and grip for a controlled hold while eating from.

Durable:

Premium materials & construction.

Performance:

Double-wall vacuum insulation with No-Sweat Design.
Exceptional thermal performance keeping contents hot.
Simple solution for venting pressure.

Easy to Use:

Dishwasher safe

RAMBLER FOOD BOWLS

Everyday use or for hosting, vacuum insulated bowls with lids to consume and serve food outdoors.



1 qt
0,95L
40€/£35



2 qt
1,9L
50€/£45



4.5 qt
4,25L
80€/£70

Serving

Individual Consumption

Sizes that are most frequently used for individual consumption.

Comparable to traditional houseware sizes of cereal, soup, pasta, and noodle bowls.

YETI is addressing consumer needs with familiar individual consumption capacities.

The large size is exclusively used for serving.

It is stationary after set on the Tableware.

YETI adds thoughtful features for a premium consumer experience.

RAMBLER BOWLS

PRODUCT OVERVIEW AND GO-TO-MARKET



D2C LAUNCH

6/17



WHOLESALE LAUNCH

6/17

INLINE COLORS



WHITE



1, 2, 4.5qt



NAVY



1, 2, 4.5qt



1 qt
0,95L
40€/£35

2 qt
1,9L
50€/£45

4.5 qt
4,25L
80€/£70

REASONS TO BELIEVE

Design:

Extension of YETI's elevated design language within the Tableware assortment.

Durable:

Premium materials & construction.

Performance and versatility:

Double-wall vacuum insulation and transparent lid to retain temperature.

Indoor & Outdoor uses with hot and cold contents to prep, consume and serve. Stackable storage.

Easy to Use:

Dishwasher safe

GATHERING

KEY AREAS OF GROWTH

BARWARE

TABLEWARE

CHAIRS

LOWLANDS

HARD COOLERS

COFFEE

YETI





'GATHERING' THEME
NEW PRODUCTS



CHAIR PORTFOLIO



**Trailhead
Field Chair**

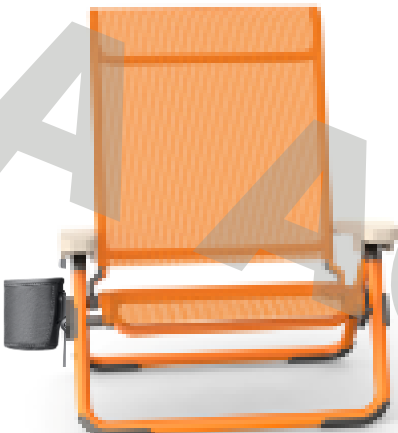

**Hondo
Beach Chair**



**Trailhead
Camp Chair**

YETI TRAILHEAD[®] FIELD CHAIR

CONSUMER NEED

Committed parents, fans, and outdoorsmen deserve the best seats in the house: seats that won't quit, collapse at the end of the season, or succumb to the elements. The field chair is compact, easily carries, and doesn't compromise on comfort or durability.

CONSUMER TARGET

Outdoor people whose packed calendars require packing for anything.

FROM FIELDS TO STREAM, WE'VE PERFECTED THE PERCH.

COMPACT

Quad-folding architecture means you can throw a few in the trunk.

DURABILITY

Built to be used hard season after season and stand up to the elements.

PORTABILITY

Our lightest chair yet, and easy to haul with a carry bag.



YETI[®] TRAILHEAD[®] FAMILY



CAMP CHAIR

FIELD CHAIR

COMPATIBLE ACCESSORIES



Trailhead[®] Cup Holder
Sold separately



Rambler[®] 20 oz Tumbler



Rambler[®] 25 oz Straw Mug



Lowlands[®] Blanket

TRAILHEAD FIELD CHAIR

PRODUCT OVERVIEW AND GO-TO-MARKET



D2C LAUNCH

10/21



WHOLESALE LAUNCH

10/21



230€/£200

INLINE COLORS

 OLIVE



 TAN



REASONS TO BELIEVE

Portable:

This chair is built to take everywhere and is light, collapses small, and is easy to carry

Comfortable:

Best in class comfort and easy to get in and out of

Durable:

Built to last construction and materials for multi-season durability

Versatile:

The field chair is compact, easily carries, and doesn't compromise on comfort or durability.

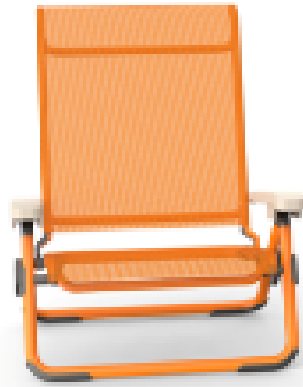

Trailhead Field Chair

Hondo Beach Chair

Trailhead Camp Chair

Price 230€/£200

280€/£250

340€/£300

Product weight ±4,5kg

4,5kg

5,9kg

Weight capacity 350 lbs / 158kg

350 lbs / 158kg

500 lbs / 226kg

Material Aluminum frame
plain-weave seat

Aluminum frame and
Quantum seat

Aluminum frame and
Quantum seat

Style Quad-fold

Bi-fold

Quad-fold

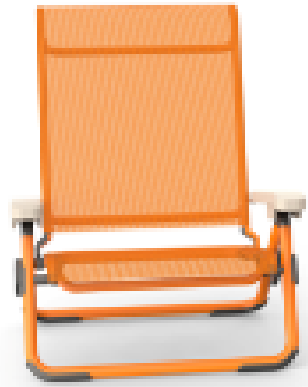

EMMEE AGENTS

Trailhead Field Chair

Hondo Beach Chair

Trailhead Camp Chair

Armrests

NO

YES

YES

Cup holder included?

NO

YES

YES

Recline?

NO

YES

NO

Included carry solution

Carry bag with single shoulder strap

Removeable shoulder strap (same as Hopper strap)

Carry bag with backpack straps

Primary use cases

Lives in the trunk and goes anywhere

Beach/lake

Campsite

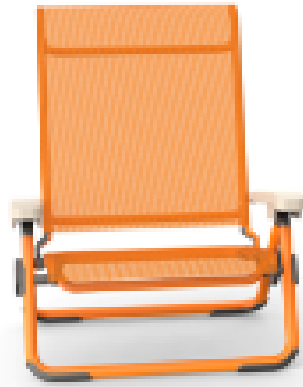

Trailhead Field Chair

Hondo Beach Chair

Trailhead Camp Chair



OLIVE



KING CRAB



NAVY



TAN



NAVY



CHARCOAL

Hondo Beach Chair

Backpack harness for Hondo Beach Chair

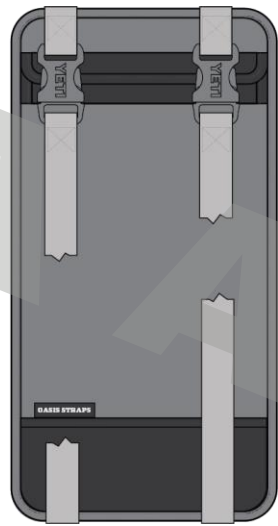
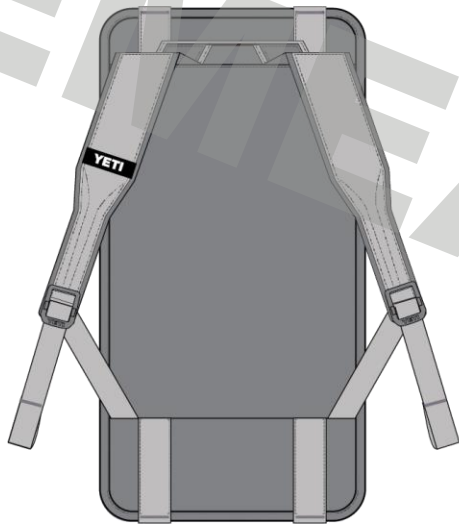

35€/£30



YETI

WARRIORS

COOLERS



HARD COOLERS | PORTFOLIO ARCHITECTURE

YETI's Hard Cooler Product lines share inherent YETI tenets of durability, performance & user experience. Collection differentiation occurs within primary use case, consumer priorities, and product features.

	KEY STORY	SECONDARY BENEFITS	ICE USE	EXAMPLE USE CASES
<p>ROADIE coolers are optimized for mobility, critical for crowded or mixed terrain.</p>	<p>MOBILITY Cold on the Go</p>	<p>Lighter Weight Easy Access Ice for Days</p>	<p>WET ICE MANDATORY 100% OF THE TIME</p>	<p>Tailgate Beach Day Road Trip Sports Sideline</p>
<p>TUNDRA coolers prioritize durability and are primarily used in active pursuit being continuously exposed to the wild.</p>	<p>DURABILITY Legendary Toughness</p>	<p>Performance In The Harshest Environments Bear Resistant Ice for Days</p>	<p>WET ICE MANDATORY 100% OF THE TIME</p>	<p>Hunt Expedition Fishing Trip Rafting Excursion Extreme Pursuit</p>





YETI[®] ROADIE[®] SPIGOT

CONSUMER NEED

The spigot accessory gives Roadie[®] owners another way to optimize their cooler investment. Not only do drinks go in 'em - now you can drink out of 'em.

CONSUMER TARGET

Roadie[®] owners who indulge in a variety of indulgences.

DISPENSE WITH AUTHORITY

IMMEDIATE SATISFACTION

Easy install, easy removal.
Innovative design to simplify
useability.

VOLUME CONTROL

Adjust stream with a turn
as you pour.

SPIGOT- 9/16
40GBP/45EUR

YETI[®] ROADIE[®] SPIGOT



COMPATIBLE ACCESSORIES



RAMBLER[®] 64oz Pitcher



Rambler[®] 10 oz Tumbler



Rambler[®] 16 oz Stackable Cup



Tie-down Kit

DURASIP™ CERAMIC LINING



**TWIST-TO-LOCK
MAGSLIDER™ LID**



**ALL RAMBLER®
DRINKWARE:**

- DOUBLE-WALL VACUUM INSULATED
- 18/8 STAINLESS STEEL
- DISHWASHER SAFE

34oz PITCHER

EXTENSION OF THE PITCHER OFFERING IN 2H25
34 AND 64oz

RAMBLER® 34 Pitcher/ 1L



£ 80/ 100€

RAMBLER® 64 Pitcher/ 1,9L



£ 100/ 120€



COMPATIBLE WITH THE FRENCH
PRESS LID FOR A 2:1 COMBO

2H25 COLOR

BLACK FOREST
GREEN

CHERRY BLOSSOM

WETLANDS CAMO

SOLAR FLARE

TUMBLEWEED

FULL YEAR 2025 - COLOR REVIEW

2025 CALENDAR

JAN FEB MAR APR MAY JUN JULY AUG SEP OCT NOV DEC

BASIC



BIG SKY BLUE



BLACK FOREST GREEN

CORE COLOR



ULTRAMARINE VIOLET



PEACH/BEEKEEPER



SUMMER COLOR



"SOLAR FLARE"

SPORTY/ BRIGHT



FIREFLY



RESCUE RED



WETLANDS CAMO

CORE PURSUIT



CHERRY BLOSSOM



TUMBLEWEED

LIFESTYLE



EMEA AGENTS

BLACK FOREST

Tim Adams and Ashleigh Carter make a pilgrimage to the historic old breweries of the Black Forest in Germany and venture off the beaten path for some outdoor excursions.

2H25 "INSPIRED BY" COLOR



THE BLACK FOREST COLLECTION

SKU Name: Black Forest Green

Tim Adams and Ashleigh Carter make a pilgrimage to the historic old breweries of the Black Forest in Germany and venture off the beaten path for some outdoor excursions.

Themes:
International travel
Food and beverage
Fishing and hiking
Fall Oktoberfest

BLACK FOREST GREEN ASSORTMENT LIST

DRINKWARE

Flask
Shot Glasses
 Rambler 10 oz Mug
 Rambler 10 oz Wine
 Rambler 4 oz Stackable Cups
 Rambler 6 oz Stackable Mugs
 Rambler 8 oz Stackable Tumbler
 Rambler 16 oz Stackable Cup
 Rambler 20 oz Stackable Cup
 Rambler 10 oz Tumbler
 Rambler 20 oz Tumbler
 Rambler 20 oz Travel Mug
 Rambler 25 oz Mug w/ Straw
 Rambler 35 oz Mug w/ Straw
 Rambler 42 oz Mug w/ Straw

DRINKWARE ACCESSORIES

MagSlider Pack

BOTTLES

Rambler 12 oz Kids Bottle
 Rambler 12 oz Travel Bottle
 Rambler 16 oz Travel Bottle
 Rambler 18 oz Bottle w/ Chug
 Rambler 18 oz Bottle w/ Colored Straw
 Rambler 26 oz Bottle w/ Chug
 Rambler 26 oz Bottle w/ Colored Straw
 Rambler 36 oz Bottle w/ Chug
 Rambler 46 oz Bottle w/ Chug
 Rambler 64 oz Bottle w/ Chug

Yonder .75 L Bottle
Yonder .75 L Bottle w/ Colored Straw
Yonder 1 L Bottle

BOTTLE ACCESSORIES

Bottle Sling Small
Bottle Sling Large

TABLEWARE

Rambler Cocktail Shaker
 Rambler 34 oz French Press
 Rambler 64 oz French Press

Rambler Food Jar 8 oz
Rambler Food Jar 16 oz
Rambler Food Jar 24 oz
Rambler Food Jar 40 oz

HARD COOLERS

Roadie 15
Roadie 24 2.0
Tundra 45
Tundra Haul

SOFT COOLERS

Hopper Flip 8
Hopper Flip 12
Hopper Flip 18
Hopper M12 Backpack
Hopper M20 Backpack
Hopper M15 Tote
Hopper M30 Tote

EQUIPMENT

LoadOut GoBox 15
LoadOut GoBox 30
LoadOut GoBox 60
LoadOut Bucket

APPAREL

Hat
Patch

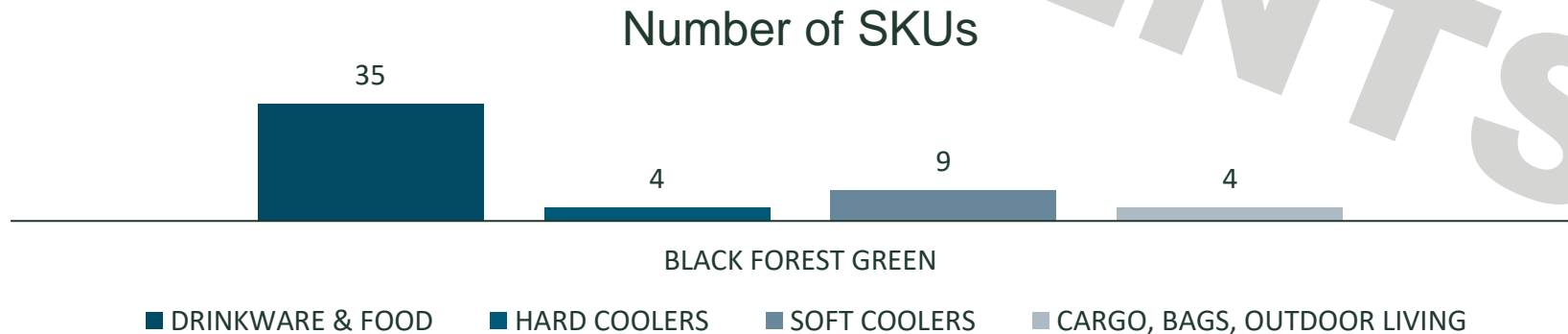

2H25 "INSPIRED BY" COLOR



THE BLACK FOREST COLLECTION

YETI HISTORICAL GREEN HUE



Olive



River



Chartreuse



Northwoods



Sagebrush



Aquifer



Highlands



Canopy



Agave Teal



Black Forest



River Green



Chartreuse



Sagebrush



Aquifer



Highlands



Canopy



Agave Teal



Black Forest



River Green



Sagebrush



Aquifer



Highlands



Canopy



Agave Teal



Agave Teal



Black Forest

CHERRY

BLOSSOM



THE CHERRY BLOSSOM COLLECTION

SKU Name: Cherry Blossom

The cherry blossom (桜, sakura) is Japan's unofficial national flower. We'll travel with YETI ambassador, Taku, to the freshwater lakes outside Tokyo to take in the spectacular spring bloom. Taku will share some of his favorite foods and tackle shops. Then we'll set out on the water. Taku says, "smallmouth bass love Taku and Japanese baits like Sushi!"

Themes:
International travel
Bass fishing
Food and beverage

CHERRY BLOSSOM ASSORTMENT LIST

DRINKWARE

Rambler 10 oz Mug
 Rambler 10 oz Wine
 Rambler 4 oz Stackable Cups
 Rambler 6 oz Stackable Mugs
 Rambler 8 oz Stackable Tumbler
 Rambler 16 oz Stackable Cup
 Rambler 20 oz Stackable Cup
 Rambler 10 oz Tumbler
 Rambler 20 oz Tumbler
 Rambler 20 oz Travel Mug
 Rambler 25 oz Mug w/ Straw
 Rambler 35 oz Mug w/ Straw
 Rambler 42 oz Mug w/ Straw

DRINKWARE ACCESSORIES

MagSlider Pack

BOTTLES

Rambler 12 oz Kids Bottle
 Rambler 12 oz Travel Bottle
 Rambler 16 oz Travel Bottle
 Rambler 18 oz Bottle w/ Chug
 Rambler 18 oz Bottle w/ Colored Straw
 Rambler 26 oz Bottle w/ Chug
 Rambler 26 oz Bottle w/ Colored Straw

TABLEWARE APPAREL

Rambler Wine Chiller
 Hat
 Patch

Number of SKUs



2H25 "INSPIRED BY" COLOR



THE CHERRY BLOSSOM COLLECTION

YETI HISTORICAL PINK HUE



Ice Pink



Prickly Pear



Sandstone



Bimini



Power



Cherry Blossom



EMEA AGENTS

THE WETLANDS COLLECTION

2H25 "INSPIRED BY" COLOR



THE WETLANDS COLLECTION

WETLANDS CAMO ASSORTMENT LIST

DRINKWARE

Flask
Shot Glasses
Rambler 10 oz Tumbler
Rambler 20 oz Tumbler

BOTTLES

Rambler 18 oz Bottle w/ Chug
Rambler 18 oz Bottle w/ Straw
Rambler 26 oz Bottle w/ Chug
Rambler 26 oz Bottle w/ Straw
Rambler 36 oz Bottle w/ Chug
Rambler 46 oz Bottle w/ Chug
Rambler 64 oz Bottle w/ Chug

TABLEWARE

Rambler Food Jar 24 oz
Rambler Food Jar 40 oz *DTC ONLY

HARD COOLERS

Roadie 15
Tundra 45
Tundra Haul

SOFT COOLERS

Hopper Flip 12
Hopper M20 Backpack

EQUIPMENT

LoadOut GoBox 30
LoadOut Bucket
Lowlands Blanket

Boomer 8

BAGS

Camino 35
Sidekick Dry 3 L

APPAREL

Hat
Patch

EMVIA AGENTS

Number of SKUs

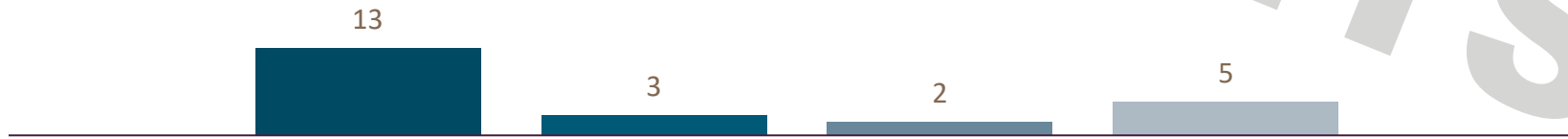

WETLANDS CAMO

■ DRINKWARE & FOOD ■ HARD COOLERS ■ SOFT COOLERS ■ CARGO, BAGS, OUTDOOR LIVING

2H25 "LIMITED" COLOR



THE WETLANDS COLLECTION

2H25 "LIMITED" COLOR



THE WETLANDS COLL

APPAREL CAPS

YETI E-commerce exclusive

NEW New 2H25 products

INLINE CAPS

YETI COOLERS
MID PRO
TRUCKER HAT



BLACK

LOGO CAMO
WOVEN FLAT
BRIM HAT



CAMO

VELCRO BADGE
FLAT BRIM
MESH HAT



GRAY/NAV
Y

YETI COOLERS
FLAT BRIM
ROPE HAT



NAVY

YETI COOLERS
FLAT BRIM
ROPE HAT



BLACK

PERFORMANCE
BASEBALL CAP



BLACK

SEASONAL OPTIONS

NEW

YETI PROST
FLAT BRIM
ROPE HAT



BROWN
BLACK FOREST
GREEN

NEW

TRUCKER HAT



GREY
CHERRY
BLOSSOM

NEW

BFTW DUCK
FLAT BRIM HAT



WETLANDS
CAMO

HATS

NEW

TRUCKER HAT



BLACK
DARK FOREST
SAND

PATCHES

SEASONAL PATCHES

NEW

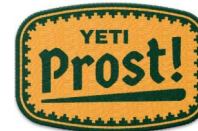

YELLOW

NEW



PINK

NEW



GOOD
DOGS
PATCH
ORANGE

SOLAR FLARE

EMEA AGENTS



2H25 "LIMITED" COLOR



SOLAR FLARE

“SOLAR FLARE” ASSORTMENT LIST

DRINKWARE

Rambler 8 oz Stackable Tumbler
Rambler 16 oz Stackable Cup
Rambler 20 oz Stackable Cup
Rambler 10 oz Tumbler
Rambler 20 oz Tumbler
Rambler 25 oz Mug w/ Straw
Rambler 35 oz Mug w/ Straw
Rambler 42 oz Mug w/ Straw

BOTTLES

Rambler 12 oz Kids Bottle
Rambler 12 oz Travel Bottle
Rambler 18 oz Bottle w/ Chug
Rambler 18 oz Bottle w/ Colored Straw
Rambler 26 oz Bottle w/ Chug
Rambler 26 oz Bottle w/ Colored Straw
Rambler 36 oz Bottle w/ Chug

EMMEA AGENTS

Number of SKUs

15



SOLAR FLARE

■ DRINKWARE & FOOD ■ HARD COOLERS ■ SOFT COOLERS ■ CARGO, BAGS, OUTDOOR LIVING

2H25 "LIMITED" COLOR



SOLAR FLARE

YETI HISTORICAL ORANGE HUE



Solar Flare

2H25 "LIMITED" COLOR

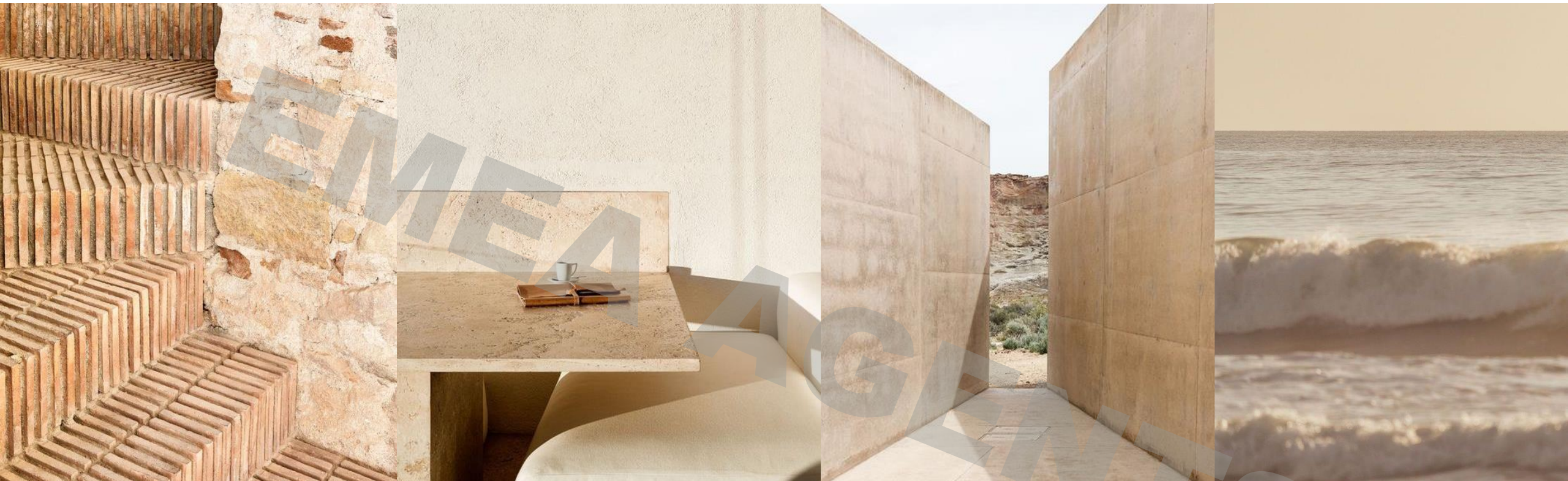

TUMBLEWEED

TUMBLEWEED ASSORTMENT LIST

DRINKWARE

Rambler 10 oz Mug
Rambler 4 oz Stackable Cups
Rambler 6 oz Stackable Mugs
Rambler 8 oz Stackable Tumbler
Rambler 16 oz Stackable Cup
Rambler 20 oz Stackable Cup
Rambler 10 oz Tumbler
Rambler 20 oz Tumbler
Rambler 25 oz Mug w/ Straw
Rambler 35 oz Mug w/ Straw
Rambler 42 oz Mug w/ Straw

TABLEWARE

Rambler 34 oz French Press
Rambler 64 oz French Press
Rambler 34 oz Pitcher
Rambler 64 oz Pitcher
Rambler Beverage Bucket
Rambler Wine Chiller

EMERGENCY AGENTS

Number of SKUs

17



SOLAR FLARE

■ DRINKWARE & FOOD ■ HARD COOLERS ■ SOFT COOLERS ■ CARGO, BAGS, OUTDOOR LIVING

2H25 "LIMITED" COLOR



TUMBLEWEED

HISTORICAL OVERVIEW

CONFIDENTIAL

DW: DRINKWARE
H: HARD COOLERS
SC: SOFT COOLERS

FALL '20	SPRING '21	FALL '21	SPRING '22	FALL '22	SPRING '23	FALL '23	SPRING '24	FALL '24	SPRING '25	FALL '25
----------	------------	----------	------------	----------	------------	----------	------------	----------	------------	----------

RED

HARVEST
DW / HC / SC

RESCUE
DW / HC

WLD VINE
DW / HC / SC

RESCUE
SC

ORANGE

KING CRAB
DW / HC / SC

HIGH DESERT
DW / SC

KING CRAB
DW / HC / SC

PEACH
SC

SOLAR FLARE
DW

YELLOW

ALPINE
DW / HC / SC

FIREFLY
DW / HC / SC

GREEN

NORTHWOODS
DW
SAGEBRUSH
DW / HC / SC

AQUIFER
DW / HC / SC

HIGHLANDS
DW / HC / SC

CANOPY
DW / HC / SC

CAMP
DW / HC / SC

AGAVE
DW / HC / SC

KEY LIME
DW / HC / SC

BLACK FOREST
DW / HC / SC

BLUE

OFFSHORE
DW

NORDIC
DW / HC / SC

BIG WAVE
DW / HC / SC

BIG SKY BLUE
DW / HC / SC

PURPLE

NORDIC
DW / HC / SC

COSMIC
DW / HC / SC

ULTRA VIOLET
DW / HC / SC

PINK

ICE PINK
DW / HC / SC

PRICKLY PEAR
DW / HC / SC

SANDSTONE
DW

BIMINI
DW / HC / SC

POWER
DW / HC / SC

SANDSTONE
DW / HC / SC
POWER
DW / HC / SC

CHERRY BLOSSOM
DW

NEUTRALS
YETI

SHARPTAIL
DW

ALL BLACK
HC / SC

WETLANDS
DW / HC / SC

WETLANDS
DW / HC / SC

CAPE TAUPE
DW / SC

TUMBLEWEED
DW























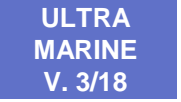

H2 2025 ACCOUNT MARKETING SUPPORT

COLOUR LAUNCHES

BLACK FOREST 7/1	CHERRY BLOSSOM 7/1	WETLANDS CAMO 8/5	SOLAR FLARE 8/26	TUMBLEWEED 11/4
H-Frame	H-Frame	H-Frame		
Branding	Branding			
Cube	Cube			
Strutcard	Strutcard	Strutcard	Strutcard	Strutcard
Digital assets	Digital assets	Digital assets	Digital assets	Digital assets
Combined	Assets			

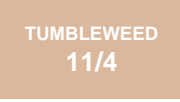
OVERALL CALENDAR

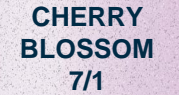
2025 ROADMAP

	JAN	FEB	MAR	APR	MAY	JUN	JULY	AUG	SEP	OCT	NOV	DEC
DRINKWARE	 Y. STRAW - 1/14		 POUR OVER - 3/18				 TRAVEL BOTTLE JUG 2.0 - 7/15					
FOOD						 FOOD JARS 8 & 16 FOOD BOWL 6/17		 FOOD JARS 24&40 8/12				
HARD COOLERS				 ROADIE 24 - 4/29					 SPIGOT - 9/16			
SOFT COOLERS & BAGS		 RANCHERO - 3/4		 CAYO - 5/20	 DAYTIP 5/6/14L	 DAYTRIP 3L						
CARGO & OUTDOOR LIVING					 BEACH CH. - 5/20				 GO BOX MICRO - 10/7	 FIELD CHAIR - 10/21		
ACCESSORIES												
COLOR		 FIREFLY YELLOW 2/18	 ULTRA MARINE V. 3/18	 PEACH/ BEEKEEPER 4/22	 RESCUE R. SG. 5/6	 BACK TO SCHOOL 6/3	 BLACK FOREST 7/1	 WETLANDS CAMO 8/5			 TUMBLEWEED 11/4	
		 BIG SKY BLUE 2/18					 CHERRY BLOSSOM 7/1	 SOLAR FLARE 8/26				

FULL YEAR CALENDAR

Q1	Product	Color
JANUARY	7	
	14	Y. STRAW
	21	
FEBRUARY	4	
	11	
	18	FIREFLY YEL. / BIG SKY BLUE
MARCH	25	
	4	RANCHERO
	11	
	18	POUR OVER / ULTRA MARINE VIOLET
	25	

Q2	Product	Color
APRIL	1	
	8	
	15	
MAY	22	PEACH/BEEKEEPER
	29	ROADIE 24
	6	
JUNE	13	
	20	CAYO BEACH CHAIR / RESCUE RED SG
	27	
	3	Daytrip 5/6/14L / BACK TO SCHOOL
	10	
	17	FOOD BOWL
	24	

Q3	Product	Color
JULY	1	Daytrip 3L / BLACK FOREST / CHERRY BLOS.
	8	
	15	TRAVEL BOTTLE JUGS 2,0
AUGUST	22	
	29	
	5	WETLAND CAMO
SEPTEMBER	12	FOOD JARS
	19	
	26	SOLAR FLARE
	2	
	9	
	16	SPIGOT
	23	
	30	

Q4	Product	Color
OCTOBER	7	GO BOX MICRO
	14	
	21	FIELD CHAIR
NOVEMBER	28	
	4	TUMBLEWEED
	11	
DECEMBER	18	
	25	
	2	
	9	
	16	
	23	
	30	