



YETI

BUILT FOR THE WILD.[™]



EMERGENCY EVENTS

YETI

1H25

ESTE DOCUMENTO ES CONFIDENCIAL

TE RECORDAMOS QUE ESTA INFORMACIÓN NO ES PÚBLICA, ES CONFIDENCIAL Y POR LO TANTO, SU DIFUSIÓN NO ESTÁ PERMITIDA NI TAMPOCO, HACER NINGÚN TIPO DE PUBLICACIÓN DE LA MISMA. ESTA INFORMACIÓN DEBE PERMANECER EN PRIVADO.

QUALQUIER DIVULGACIÓN DE ESTE DOCUMENTO INCURRIRIA EN UNA VIOLACIÓN D CONTRATO ENTRE MARCA Y CLIENTE. POR TANTO, SI NO SE RESPETA LA CONFIDENCIALIDAD, PODRÍA RESULTAR EN LA FINALIZACIÓN DE LA RELACIÓN COMERCIAL. ADEMÁS, LA MARCA PODRÍA HACER USO DE TODAS LAS ACCIONES LEGALES PERTINENTES QUE CONSIDERARA OPORTUNAS.

USA ESTE DOCUMENTO EN ESTRICTA CONFIDENCIALIDAD Y DE ESTA MANERA PROTEGEREMOS LA MARCA, CONSERVANDO EL SECRETO DE SUS NUEVOS COLORES Y PRODUCTOS HASTA EL DÍA DE SU LANZAMIENTO.

NEW PRODUCTS IN FOOD CATEGORY



FOOD JARS



FOOD BOWLS

RAMBLER FOOD JAR OPPORTUNITY

CONSUMERS NEED A YETI FOOD JAR SOLUTIONS FOR THEIR PURSUITS ACROSS EVERYDAY TO EXPEDITION.

YETI HAS MASTERED KEEPING FOOD COLD AND NOW IT'S TIME WE OFFER SOLUTIONS TO KEEP FOOD HOT.



RAMBLER FOOD JARS



RAMBLER FOOD JARS

YETI'S GIVENS



- Double-wall vacuum insulation
- 18/8 Kitchen grade stainless steel
- Seamless vessel construction with DuraCoat Color
- Dishwasher Safe
- Food Safe & BPA Free
- All Sizes available for Customization

RAMBLER FOOD JARS

JAR SPECIFIC FEATURES

- ❑ Double-wall vacuum insulation
- ❑ 18/8 Kitchen grade stainless steel
- ❑ Seamless vessel construction with DuraCoat Color
- ❑ Dishwasher Safe
- ❑ Food Safe & BPA Free
- ❑ All Sizes available for Customization



- ❑ 100% Leakproof seal
- ❑ Insulated and internal threaded Lid
- ❑ Best in Class Cleanability with the Power of Magnets
- ❑ Two-piece Lid construction delivers a seamless open and install experience
- ❑ Internal Measurement Marks

!Do not use in the microwave!

RAMBLER FOOD JARS

PRODUCT DETAILS

Collection of four sizes to address consumer capacity needs.

Portfolio compatibility across Soft Coolers and Bags.

Larger sizes include bottom hand pocket for controlled grip for direct consumption

Weight of the lids:

Small 155g

Large: 317g

Stacking by Lid Size with Lids Installed

Lid Insulation to ensure contents stay hot or cold for as longer

Molded EPS foam insert

Similar to triple haul cap, jug lid, and hotshot



RAMBLER FOOD JARS

INTERNAL MEASUREMENTS

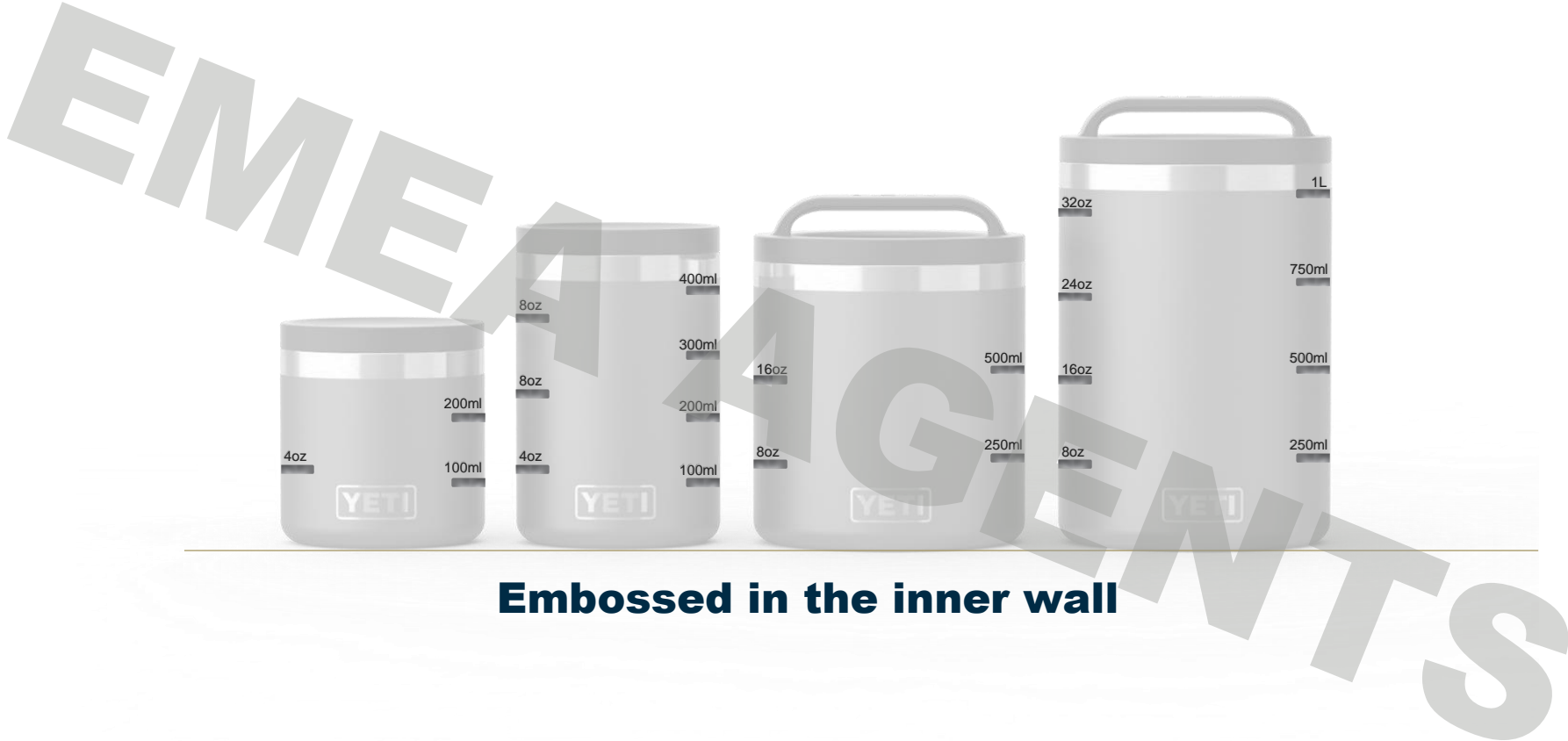

RAMBLER FOOD JARS

PRODUCT DETAILS

Closed

Quarter Turn for Venting no extra steps needed, seamless experience

Removal of Lid



Pull apart two-piece lid construction held together by magnets, allows for thorough cleaning. No special tools or inaccessible food traps.

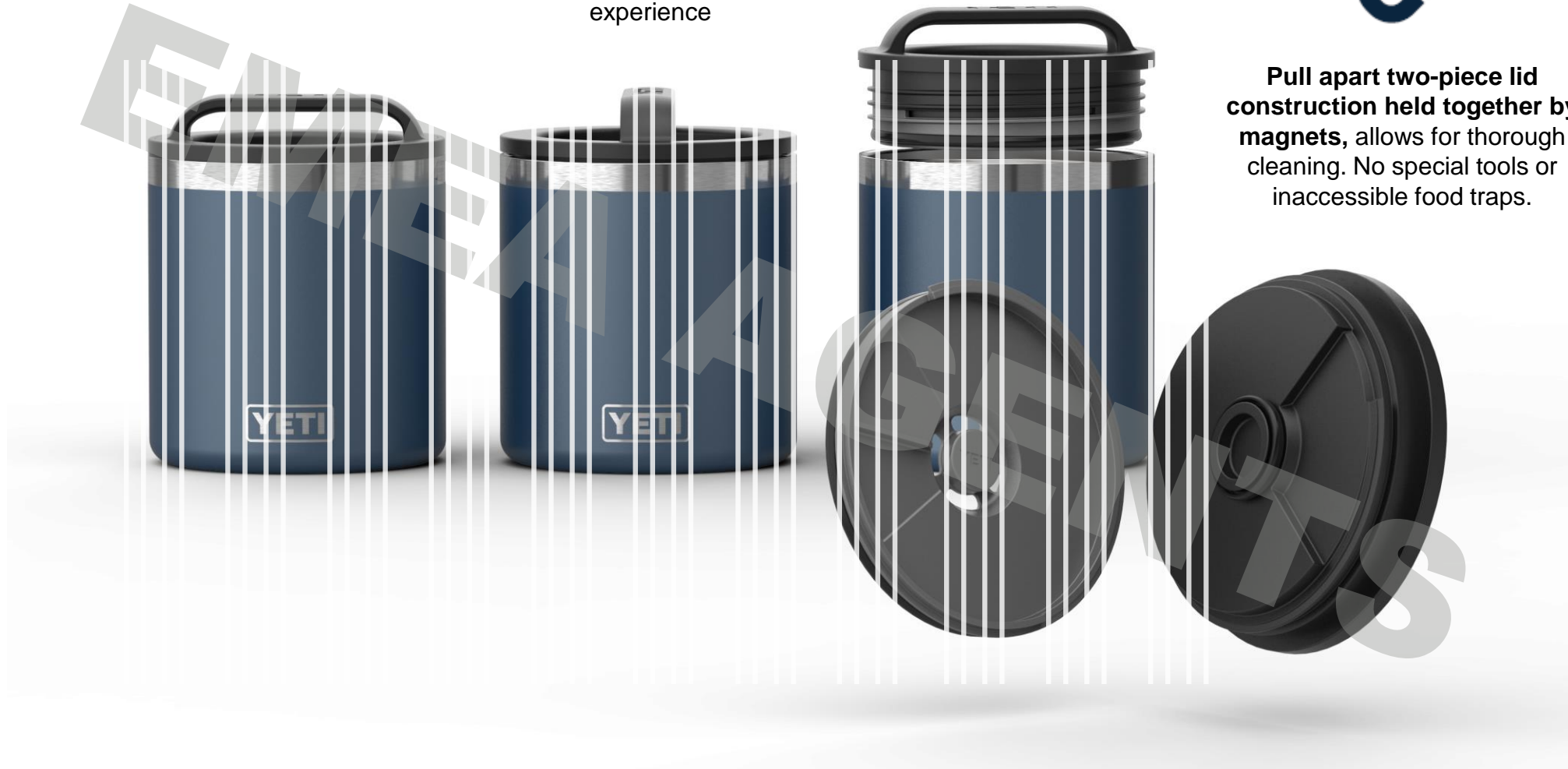

RAMBLER FOOD JARS

METRICS AND SPECS



Size	8oz 1 Cup 236mL	16oz 2 Cup 473mL	24oz 3 Cup 709mL	40oz 5 Cup 1,182mL
Fit in	Daytrip Bag and Box	Daytrip Bag and Box	Camino & Crossroads	Camino & Crossroads
Diameter	9,52cm	9,52cm	13,3cm	13,3cm
Weight w lid	525g	665g	1,108g	1,308g
Height (no lid)	9,3cm	13,8cm	12,7cm	16,9cm
Height (with lid)	10,5cm	15,0cm	15,9cm	20,1cm
Handle	No handle	No handle	Handle Channel	Handle Channel

RAMBLER FOOD JARS

PRODUCT OVERVIEW AND GO-TO-MARKET



D2C LAUNCH

1/14



WHOLESALE LAUNCH

1/14

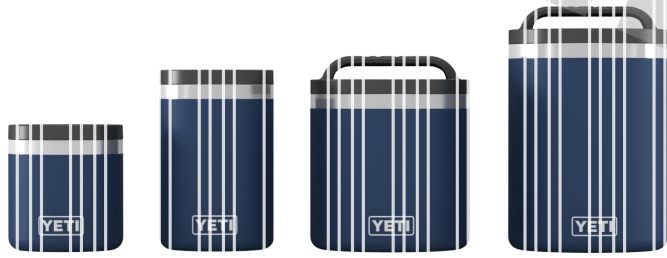

8 oz 35€/£30 16 oz 45€/£40 24 oz 55€/£50 40 oz 65€/£60

INLINE COLORS

 WHITE

 NAVY

 BLACK

 STAINLESS

 RESCUE RED

 TROPICAL PINK

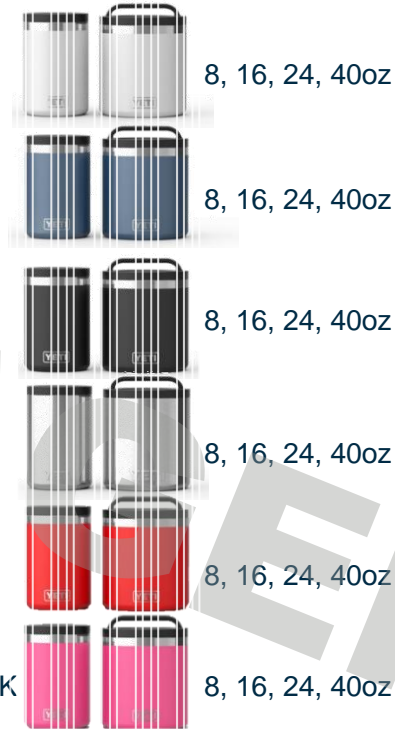

SEASONAL COLORS

 BIG SKY BLUE
2/11/25

 FIREFLY YELLOW
2/11/25



8, 16, 24, 40oz

8, 16, 24, 40oz

REASONS TO BELIEVE

Design:

Extension of YETI's elevated design language and DuraCoat compatible.
Comfort to eat directly out of the containers with utensils.
Easy to open, close, and grip for a controlled hold while eating from.

Durable:

Premium materials & construction.

Performance:

Double-wall vacuum insulation with No-Sweat Design.
Exceptional thermal performance keeping contents hot.
Simple solution for venting pressure.

Easy to Use:

Dishwasher safe



RAMBLER FOOD JARS

INSTORE POS

*All designs shown are FPO and will be finalized at a later point

RAMBLER FOOD JARS.

COMPATIBLE WITH OUR SOFT COOLERS AND BAGS

STACKABLE LIDS

MAGNETIC LID FOR EASY CLEANING

CONTROLLED GRIP WITH BOTTOM HAND POCKET
LARGER SIZES ONLY

KEEP WARM OR STAY COOL LONGER
WITH MOLDED FOAM LID INSULATION

AVAILABLE IN 4 SIZES

YETI KEEP WARM OR STAY COOL.

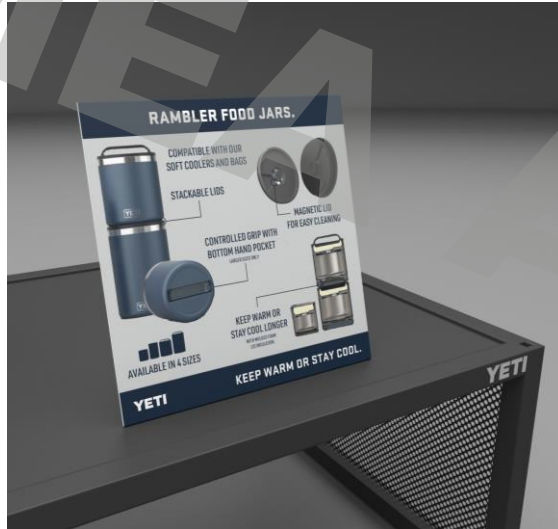

YETI

RAMBLER FOOD JARS.

DOUBLE-WALL VACUUM INSULATION

18/8 KITCHEN GRADE STAINLESS STEEL

DISHWASHER SAFE

FOOD SAFE & BPA FREE

100% LEAKPROOF SEAL

AVAILABLE IN 4 SIZES

YETI

RAMBLER FOOD JARS.

KEEP WARM OR STAY COOL

COMPATIBLE WITH OUR SOFT COOLERS AND BAGS

STACKABLE LIDS

CONTROLLED GRIP WITH BOTTOM HAND POCKET
LARGER SIZES ONLY

KEEP CONTENTS HOT OR COLD FOR LONGER
WITH EPS FOAM LID INSULATION



RAMBLER FOOD JARS

INSTORE POS – LAUNCH DATE 1/14

*All designs shown are FPO and will be finalized at a later point



SIDE BLADE

FJARS-SBLADE-ENG

FJARS-SBLADE-DE

FJARS-SBLADE-ES

FJARS-SBLADE-FR

FJARS-SBLADE-IT

STRUT CARD

FJARS-SCARD-ENG

FJARS-SCARD-DE

FJARS-SCARD-ES

FJARS-SCARD-FR

FJARS-SCARD-IT



RAMBLER BOWLS OPPORTUNITY

WE ARE A NATURAL SOLUTION IN DRINKWARE.
YETI WILL DELIVER COMPLIMENTARY FOOD-FORWARD SOLUTIONS LEADING WITH OUR
VALUABLE ATTRIBUTES ACROSS THERMAL PERFORMANCE AND DURABILITY.



RAMBLER BOWLS

YETI'S GIVENS

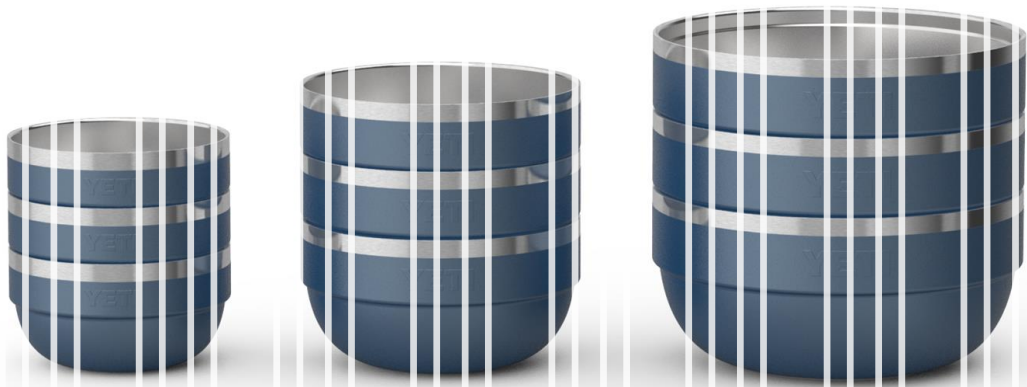

- ❑ Double-wall vacuum insulation for best-in-class thermal performance
- ❑ 18/8 Kitchen grade stainless steel
- ❑ Seamless vessel construction with DuraCoat Colorthroughout.
- ❑ 12mm stainless dermal barrier
- ❑ Dishwasher Safe
- ❑ Food Safe & BPA Free

Do not use in the microwave

RAMBLER BOWLS

BOWLS SPECIFIC FEATURES

Transparent lid to clearly see contents inside
Splash-Resistant lid for easy access while protecting contents from bugs and debris

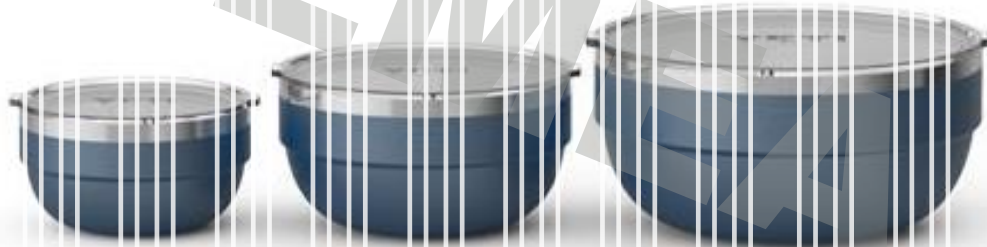

Stackable design allows for efficient storage within the same size without lids



All three sizes fully nest with lids installed for compact storing

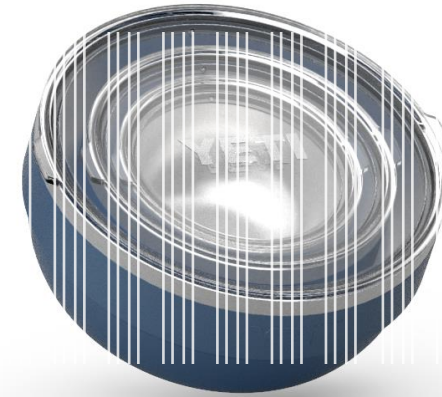

Non-Slip Foot on 4.5qt Bowl to stabilize and protect surfaces and the vessel



RAMBLER BOWLS

LID CLARIFICATION

THE LID IS

Similar to lid on beverage bucket

Same look and feel, press fit tritan renew lid that is easily removable with little force

Preventing debris entering

Used outside, some debris might enter in bowl

Mainting temperature

Helps keep warmth or cold

Designed for stationary usage

We will not advertise the lid as leakproof



THE LID IS NOT

A storage solution

NOT meant for long term storage or for long transportation.

Leakproof

The lid is not leakproof

Suitable for backpack/lunchboxes

If the bowl is upright in a bag (Camino for example), with the lid on, it should stay put



RAMBLER BOWLS

UNITS OF MEASURE

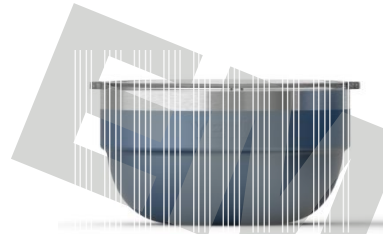

1 qt
0,95L
40€/£35



2 qt
1,9L
50€/£45

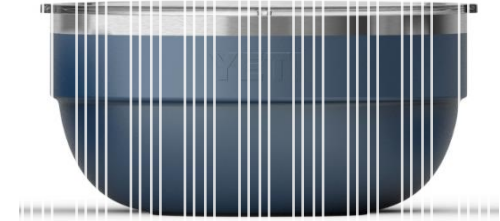

4.5 qt
4,25L
80€/£70

Unit **QUART**



RAMBLER BOWLS

USAGES

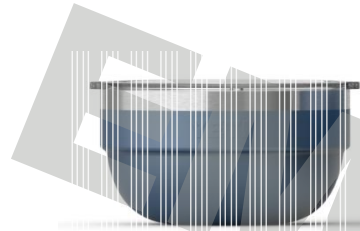

1 qt
0,95L
40€/£35



2 qt
1,9L
50€/£45

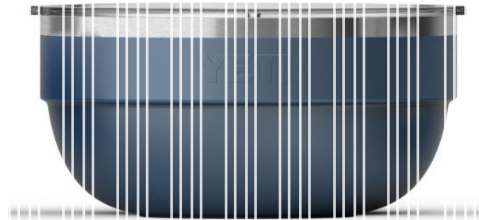

4.5 qt
4,25L
80€/£70

1 PRIMARY USE

Individual Consumption

Sizes that are most frequently used for individual consumption.

Comparable to traditional houseware sizes of cereal, soup, pasta, and noodle bowls.

YETI is addressing consumer needs with familiar individual consumption capacities.

Serving

These sizes are exclusively used for serving.

These sizes are stationary after set on the Tableware.

YETI adds thoughtful features for a premium consumer experience.

2 SECONDARY USE

Serving

Individual consumption bowl sizes can flex to be used for sharing and serving.

YETI is providing versatile product for the consumer to use.

RAMBLER BOWLS

METRICS AND SPECS

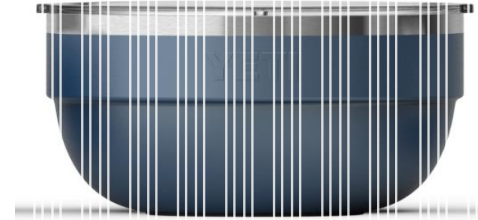
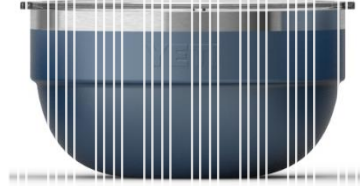

Size	1 qt / 0,95L	2 qt / 1,9L	4.5 qt / 4,25L
Weight	359g	659g	1,314g
Diameter	15,2cm	19,2cm	25,4cm
Height (no lid)	8,2cm	10,2cm	12,3cm
Height (with lid)	8,7cm	10,7cm	12,8cm

RAMBLER BOWLS

PRODUCT OVERVIEW AND GO-TO-MARKET



D2C LAUNCH

3/19



WHOLESALE LAUNCH

3/19



1 qt
0,95L
40€/£35

2 qt
1,9L
50€/£45

4.5 qt
4,25L
80€/£70

REASONS TO BELIEVE

Design:

Extension of YETI's elevated design language within the Tableware assortment.

Durable:

Premium materials & construction.

Performance and versatility:

Double-wall vacuum insulation and transparent lid to retain temperature.

Indoor & Outdoor uses with hot and cold contents to prep, consume and serve. Stackable storage.

Easy to Use:

Dishwasher safe

INLINE COLORS



WHITE



1, 2, 4.5qt



NAVY



1, 2, 4.5qt



STAINLESS



1, 2, 4.5qt



RESCUE RED



1, 2, 4.5qt



TROPICAL PINK



1, 2, 4.5qt

FOODWARE

	Price EUR/GBP	Black	Navy	White	Seafoam	Stainless	Rescue Red	Tropical Pink	Big Sky Blue	FireFly Yellow	ULTRA MARINE VIOLET
Food Storage S	15€/£12		●								
Food Storage M	20€/£16		●								
Food Storage L	28€/£24		●								
Food Jar 8oz	40€/£35	●	●	○		○	●	●	○	●	●
Food Jar 16oz	45€/£40	●	●	○		○	●	●	○	●	●
Food Jar 24oz	50€/£45	●	●	○		○	●	●	○	●	●
Food Jar 40oz	60€/£55	●	●	○		○	●	●		●	●
Bowl 1qt	40€/£35		●	○		○	●	●		●	
Bowl 2qt	50€/£45		●	○		○	●	●		●	
Bowl 4,5qt	80€/£70		●	○		○	●	●		●	

RAMBLER BOWLS

INSTORE POS

RAMBLER BOWLS.

SPLASH-RESISTANT LID
SEE CONTENTS CLEARLY

STACKABLE STORAGE (NO LIDS)

COMPACT NESTING STORAGE (WITH LIDS)

NON-SLIP FOOT (4.5QT/4.25L BOWL ONLY)

AVAILABLE IN 3 SIZES

YETI **KEEP WARM OR STAY COOL.**



YETI

RAMBLER FOOD BOWLS.

DOUBLE-WALL VACUUM INSULATION

DISHWASHER SAFE

FOOD SAFE & BPA FREE

18/8
18/8 KITCHEN GRADE STAINLESS STEEL

12MM STAINLESS DERMAL BARRIER

SPLASH-RESISTANT LID

1QT 0,95L **2QT 1,9L** **4.5QT 4,25L**

AVAILABLE IN 3 SIZES

YETI

RAMBLER FOOD BOWLS.

KEEP WARM OR STAY COOL

THERMAL PERFORMANCE AND DURABILITY

STACKABLE DESIGN ALLOWS FOR EFFICIENT STORAGE WITHIN THE SAME SIZE WITHOUT LIDS*

*All 3 sizes fully nest with lids installed for compact storing.



*All designs shown are FPO and will be finalized at a later point



RAMBLER BOWLS

INSTORE POS – LAUNCH DATE 3/19

*All designs shown are FPO and will be finalized at a later point

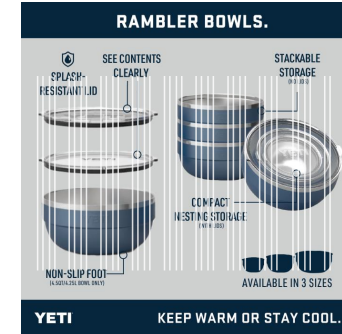

SIDE BLADE

FBOWL-SBLADE-ENG

FBOWL-SBLADE-DE

FBOWL-SBLADE-ES

FBOWL-SBLADE-FR

FBOWL-SBLADE-IT

STRUT CARD

FBOWL-SCARD-ENG

FBOWL-SCARD-DE

FBOWL-SCARD-ES

FBOWL-SCARD-FR

FBOWL-SCARD-IT



RAMBLER BOWLS & FOOD JARS

COMBINED POS – LAUNCH DATE 3/19



SIDE BLADE

FBOWL/JAR-SBLADE-ENG

FBOWL/JAR-SBLADE-DE

FBOWL/JAR-SBLADE-ES

FBOWL/JAR-SBLADE-FR

FBOWL/JAR-SBLADE-IT

YETI
RAMBLER FOOD BOWLS.

AVAILABLE IN 3 SIZES

- DOUBLE-WALL VACUUM INSULATION
- SPLASH-RESISTANT LID
- FOOD SAFE & BPA FREE
- DISHWASHER SAFE

EFFICIENT STORAGE DESIGN

STACKABLE STORAGE (NO LIDS)

COMPACT NESTING STORAGE (WITH LIDS)

KEEP WARM OR STAY COOL

SEE CONTENTS CLEARLY

NON-SLIP FOOT (L-SIZE ONLY)

YETI
RAMBLER FOOD JARS.

AVAILABLE IN 4 SIZES

- DOUBLE-WALL VACUUM INSULATION
- SPLASH-RESISTANT LID
- FOOD SAFE & BPA FREE
- DISHWASHER SAFE

COMPATIBLE WITH OUR SOFT COOLERS AND BAGS

STACKABLE LIDS

CONTROLLED GRIP WITH BOTTOM HAND POCKET (LARGE LIDS ONLY)

KEEP WARM OR STAY COOL

KEEP CONTENTS HOT OR COLD FOR LONGER WITH MOLDED EPS FOAM INSERT LID INSULATION

EASY TO CLEAN PULL APART TWO-PIECE LID CONSTRUCTION HELD BY MAGNETS

INTERNAL MEASUREMENTS

*All designs shown are FPO and will be finalized at a later point

RAMBLER FOOD JARS & BOWLS

MERCHANDISING



RAMBLER FOOD JARS & BOWLS

MERCHANDISING



A close-up shot of a person's hands pouring a beverage from a white YETI water bottle into a cup. The person is wearing a white t-shirt and a gold watch. In the background, two women are sitting on a picnic table outdoors, surrounded by picnic supplies like a yellow bag and a blue cup. The scene is lit with warm, golden light, suggesting late afternoon or early evening.

BEVERAGE

BE WITH AND FOR CONSUMERS

WIND DOWN

TEQUILA SUNRISE AT
SUNSET

SET OUT

HYDRATION IN LOW
COUNTRY



WAKE UP

DARK ROAST AT FIRST
LIGHT

24HRS A DAY

YETI

RISE AND SHINE BEFORE THE GRIND



NEW POUR OVER
NEW HOTSHOT 2.0



YETI

ON-THE-GO SIPS FOR EVERY TRIP



NEW **RAMBLER® JUGS**
NEW **YONDER .75L C Straw**



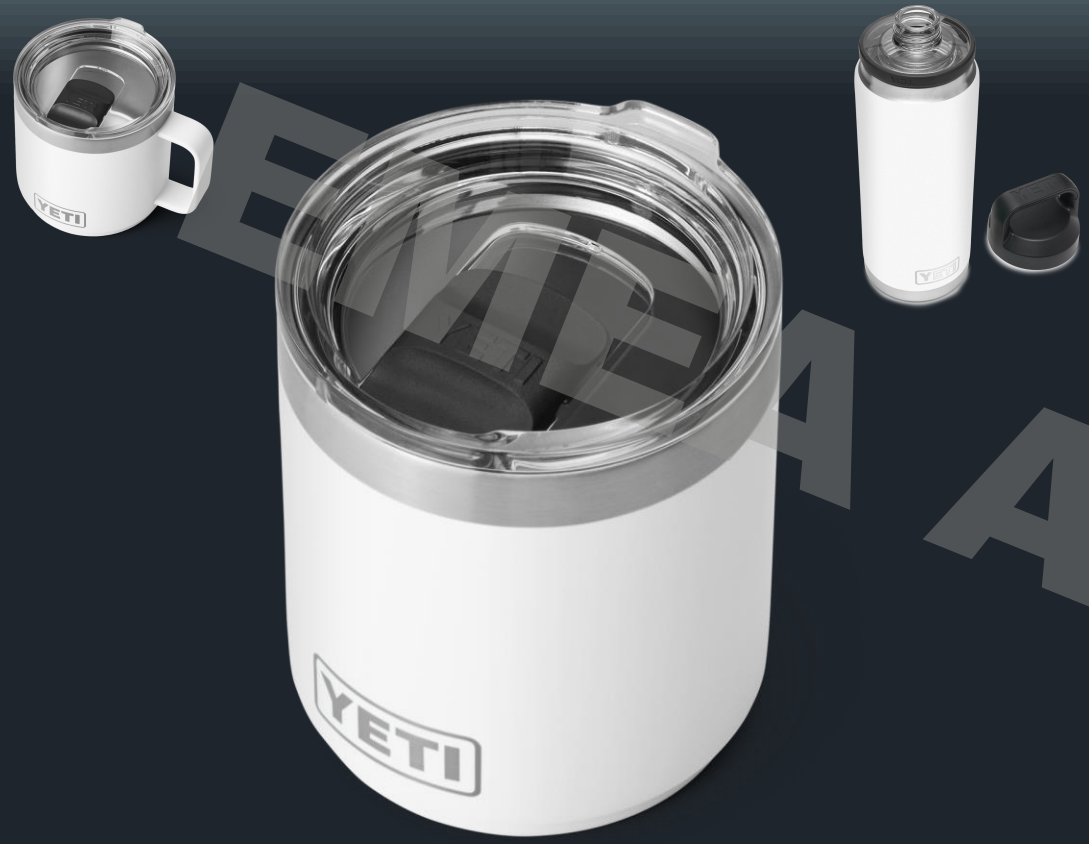

**COLD OR HOT
WHATEVER HITS
THE SPOT**

EVERY AREA AGENTS



DARK ROAST AT FIRST LIGHT

NEW POUR OVER
NEW HOTSHOT 2.0

YETI

RAMBLER HOTSHOT 2.0

PRODUCT DETAILS

Vessels: 12oz and 16oz
Designed to accommodate
global cup holders (EU/UK)



Recessed pocket to help avoid nose
collision and reduce head tilt while driving.
Channeled flow path helps direct liquid.

RAMBLER HOTSHOT 2.0

SLIMMER SILHOUETTE - LOWER PROFILE



RAMBLER HOTSHOT 2.0

PRODUCT DETAILS

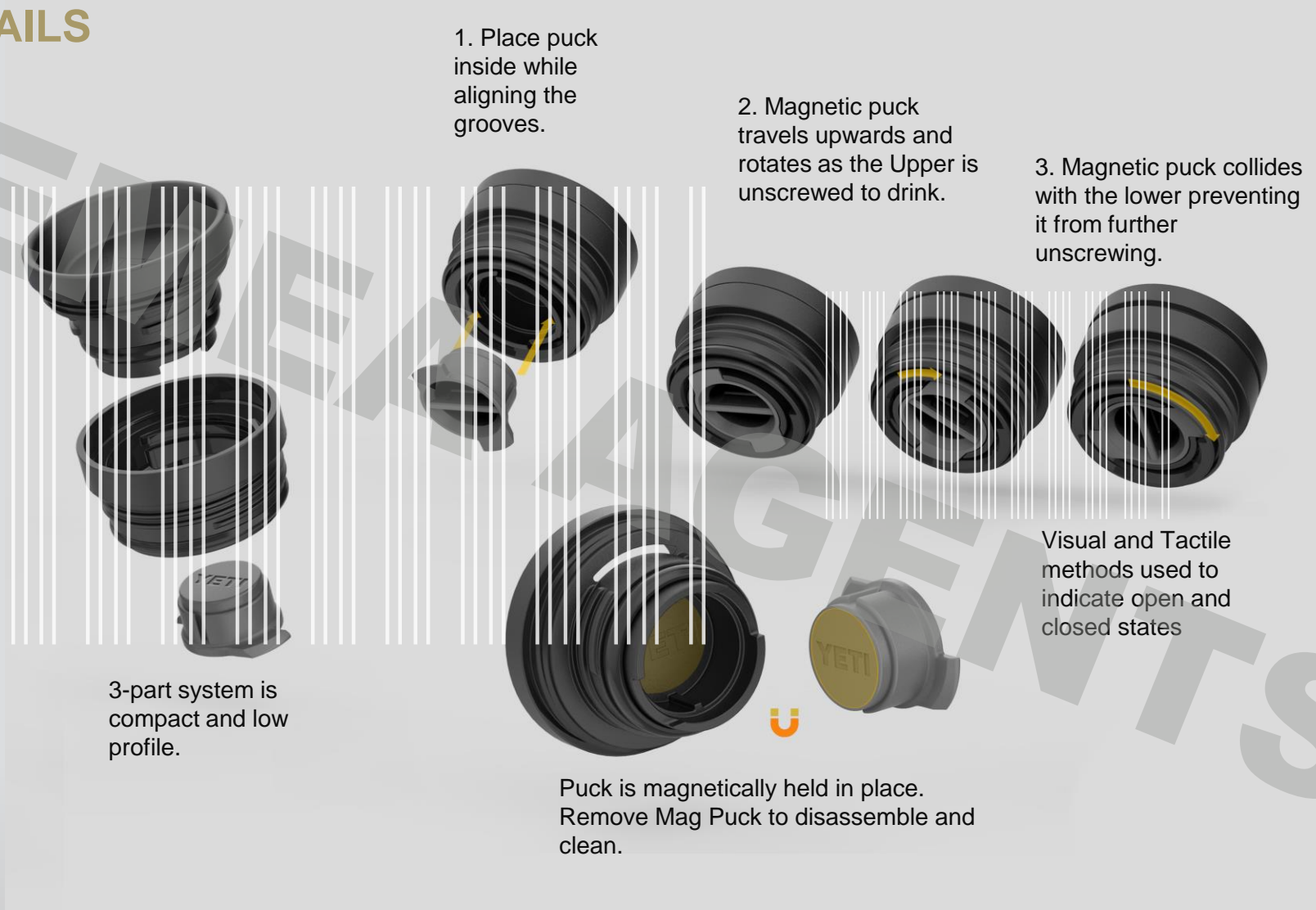

1. Place puck inside while aligning the grooves.

2. Magnetic puck travels upwards and rotates as the Upper is unscrewed to drink.

3. Magnetic puck collides with the lower preventing it from further unscrewing.

3-part system is compact and low profile.

Puck is magnetically held in place. Remove Mag Puck to disassemble and clean.

Visual and Tactile methods used to indicate open and closed states

RAMBLER HOTSHOT 2.0

PRODUCT OVERVIEW AND GO-TO-MARKET



D2C LAUNCH
2/25



WHOLESALE LAUNCH
2/25



12 oz 35€/£30
16 oz 40€/£35
20 oz 45€/£40

INLINE COLORS

-  WHITE
-  NAVY
-  BLACK
-  RESCUE RED
-  TROPICAL PINK
-  SEAFOAM



SEASONAL COLORS

-  BIG SKY BLUE
2/25/25
-  FIREFLY YELLOW
2/25/25
-  ULTRA MARINE VIOLET
3/25/25



REASONS TO BELIEVE

Design:

Refresh the current design of the HotShot bottle to reflect those within updated coffee Drinkware portfolio.

Durable:

Maintain premium materials and construction.

Performance and versatility:

Maintain vacuum insulation to keep drinks at desired temperature & leakproof lid prevents spills while on the go.

Easy to Use:

Cupholder compatible, dishwasher safe, easy lid access.



RAMBLER HOTSHOT 2.0

INSTORE POS – LAUNCH DATE 2/25

*All designs shown are FPO and will be finalized at a later point

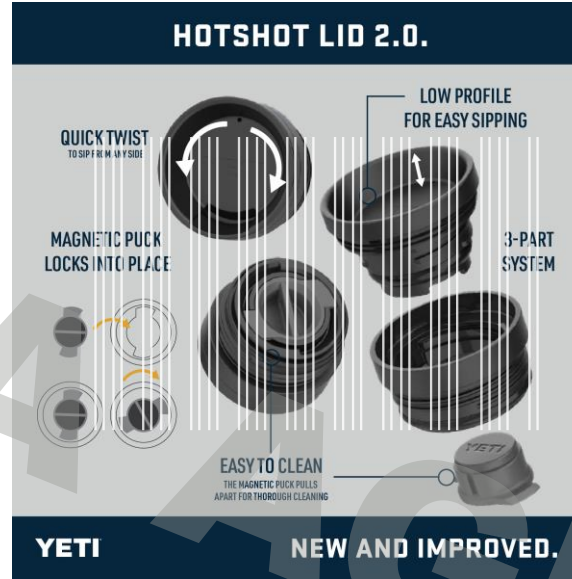

STRUT CARD

HSHOT2.0-SCARD-ENG

HSHOT2.0-SCARD-DE

HSHOT2.0-SCARD-ES

HSHOT2.0-SCARD-FR

HSHOT2.0-SCARD-IT

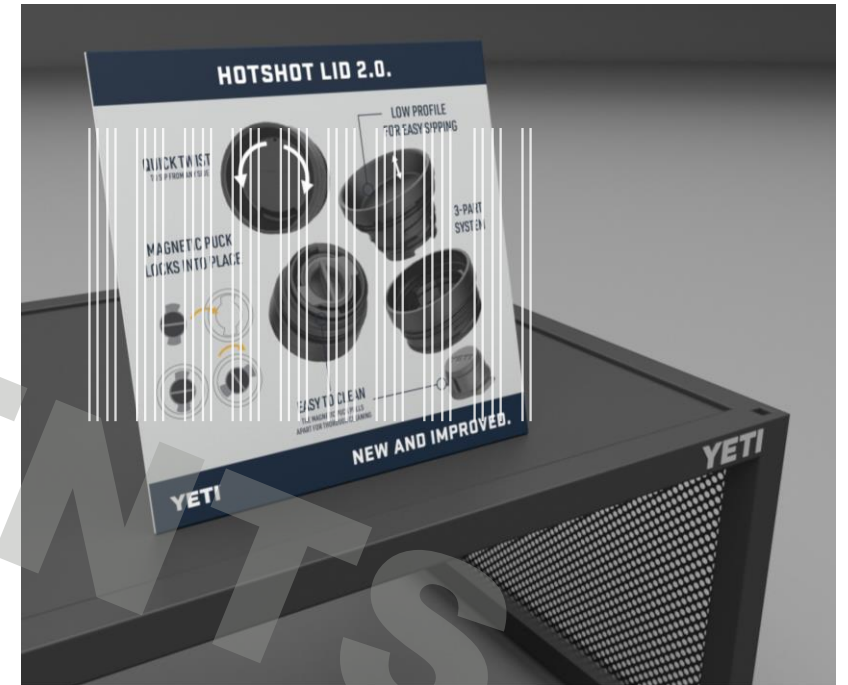

RAMBLER HOT SHOT 2.0

MERCHANDISED ON A H-FRAME GONDOLA



YETI POUR OVER

FITS ON MOST OF OUR VESSELS AND MORE...



R8

R10

R20

R10 Mug

R14 Mug

R24 Mug

YETI POUR OVER

PRODUCT DETAILS

Venting grooves allow air to pass by as water is being poured through the grounds.

Electropolished inner surfaces

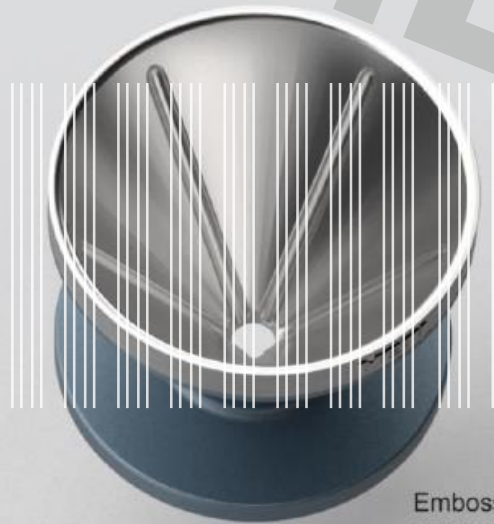

Embossed logo on upper rim

Rim helps to center the pour over and prevents it from sliding off the mug

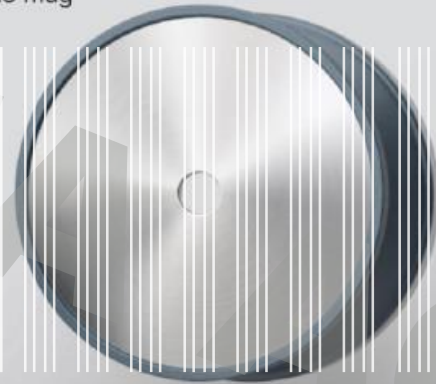

12mm hole proven to be the ideal hole size to regulate flow

Exposed SS on the underside to prevent chipping of Duracoat. Circular brush pattern applied.

Cone shape is short enough to expose the top of the filter so it can remove when finished



Duracoated exterior surfaces with 12mm rim of exposed brushed SS

YETI POUR OVER

PRODUCT OVERVIEW AND GO-TO-MARKET



D2C LAUNCH

2/4



WHOLESALE LAUNCH

2/4

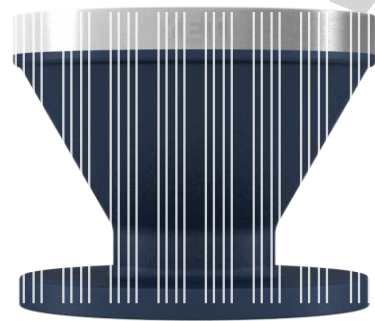

35€/£30

INLINE COLORS

 WHITE

 NAVY

 RESCUE RED

 TROPICAL PINK



REASONS TO BELIEVE

Design:

Extension of YETI's elevated design language within the Tableware assortment. Funnel shape and base fitted to existing products.

Durable:

Overbuilt with materials that are tried and true.

Performance and versatility:

Double-Wall air filled construction, not vacuum.

Easy to Use:

Pace of our is up to user. Dishwasher safe



YETI POUR OVER

INSTORE POS – LAUNCH DATE 2/4

*All designs shown are FPO and will be finalized at a later point



STRUT CARD

POVER-SCARD-ENG

POVER-SCARD-DE

POVER-SCARD-ES

POVER-SCARD-FR

POVER-SCARD-IT



YETI

YETI POUR OVER

MERCHANDISED TOGETHER WITH COFFEE



YETI

This information is non-public, confidential, and proprietary. Sharing or posting by anyone in your organization in any way violates the terms of your dealer agreement.

CONFIDENTIAL 63



HYDRATION IN LOW COUNTRY

NEW RAMBLER® JUGS

YETI

RAMBLER JUG 2.0

PRODUCT DETAILS



1.0

Design updates to the neck of the vessel



2.0

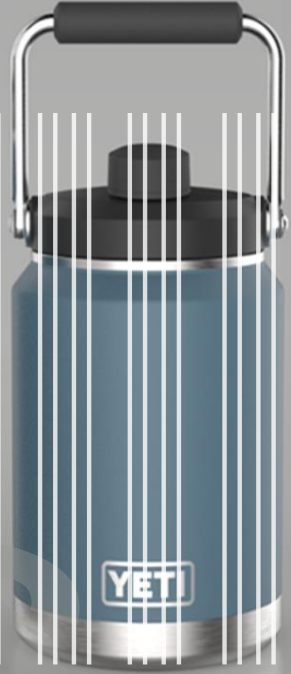

RAMBLER JUG 2.0

PRODUCT DETAILS

Anti-Glug Venting, with removable wedge for cleaning

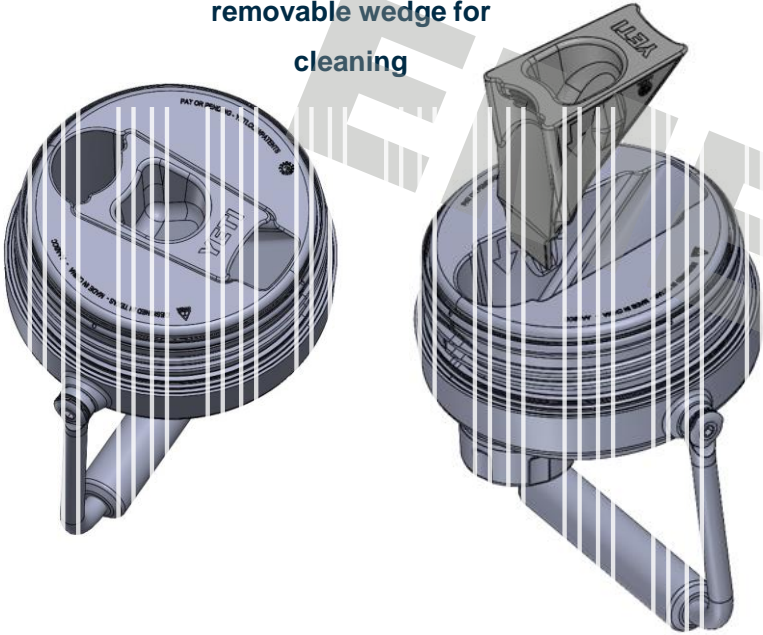

Rubber foot for better grip when pouring

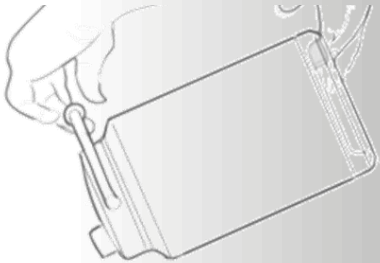
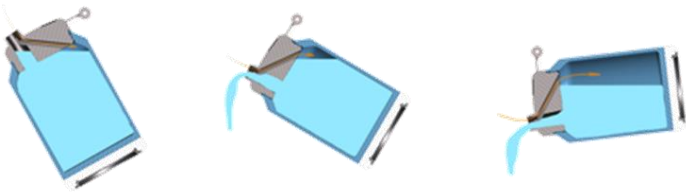

RAMBLER JUG 2.0

PRODUCT OVERVIEW AND GO-TO-MARKET



D2C LAUNCH
2/4



WHOLESALE LAUNCH
2/4



1 Gallon
150€/£130

1/2 Gallon
120€/£100

REASONS TO BELIEVE

Design:

- Improvements include
- Wave washer integration for handle indexing
- Removable vent wedge for improved flow rate & smoother pour
- Base bumper/grip ring

INLINE COLORS

 BLACK

 NAVY

 STAINLESS STEEL

 RESCUE RED

 TROPICAL PINK

SEASONAL COLORS

 FIREFLY YELLOW
3/13/25



Performance:

- Premium materials and construction that stand the test of time
- Protect the wild with longevity and sustainable materials

Versatility:

- Water storage, group sharing for hot/cold beverages



EXTENSION OF THE YONDER OFFERING

ADDING THE 0,75L STRAW OPTION TO THE MIX



Adding the 0,75L STRAW option to our Yonder offer

Also available as an accessory

Reinforcing the choice for the consumer



YONDER™

Y.75L C Straw	NEW	30€/£25
Y.75L Water Bottle - Tether		30€/£25
Y 1L Water Bottle - Tether		33€/£28



HARD COOLERS

Roadie 24 2.0 **NEW**



IN 2008....

TUNDRA®

The legendary cooler that started it all.

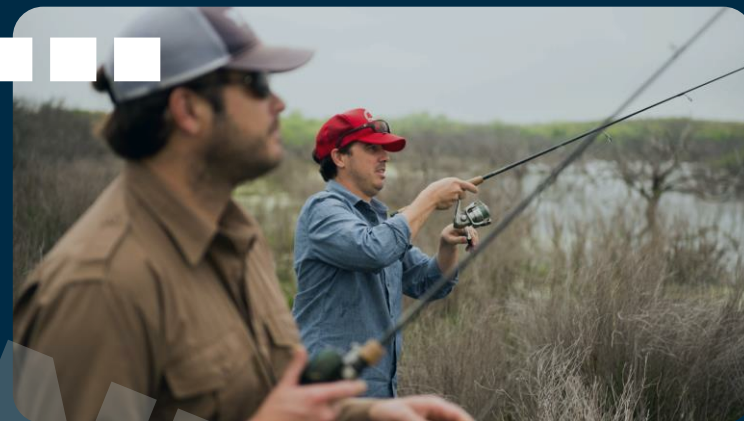

YETI



A LOOOOONG JOURNEY

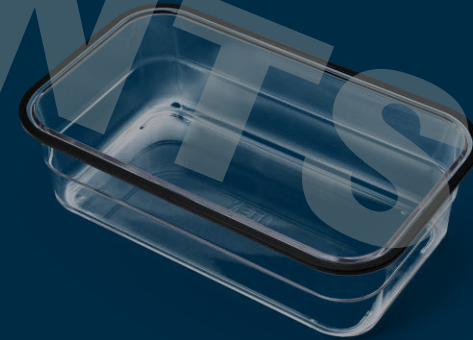

YETI



YTD
COOLERS ARE
>20% OF
THE MIX
(IN REVENUE)



YETI

SHARED

WIDE FORMAT
For a wider view

FATWALL
Extra thick and bear-resistant

ROTOMOLDED
Seamless construction

T-LATCH
Bull simple, heavy-duty

SIMPLE ACCESSORIES
Efficiency first

ALL SIZES
Covers all types of needs from week-end trip to deep-water catches storage.

DURABILITY

THERMAL PERF.

WHEELED OPTIONS

COLOR OPTIONS

CUBE DESIGN
Easy to maneuver

RETRACTABLE HANDLE
To fit in smaller vehicles

SPACE EFFICIENCY
Maximize inner volume

QUICK LATCH
Flexible, simple one-hand access

THOUGHTFUL ACCESSORIES
Divider, basket, cup-holder

START SMALL, GROW BIG
Family extension

TUNDRA



ROADIE

ROADIE FAMILY

MODEL OVERVIEW



ROADIE

15 | 24 | 32 | 48 | 60

ROADIE 24

UPGRADES

NEW Convertible Shoulder Strap / Handle
(same as R15)

NEW Roadie 48/60
Gasket Design

Roadie Wheeled Cooler
Lockport Compatible

Roadie 24 Dry
Goods Basket

QUICKLATCH™ Access

ANCHORPOINT™
Tie-Down Slots

LIPGRIP™ Handles

NEW BESTDAM™ Drain Plug

BEARFOOT™ Non-Slip Feet

ROADIE 24

PRODUCT OVERVIEW AND GO-TO-MARKET



D2C LAUNCH

3/25



WHOLESALE LAUNCH

3/25



250€/£225

INLINE COLORS

 WHITE

 NAVY

 CHARCOAL

 TAN

 RESCUE RED



SEASONAL COLORS

 BIG SKY BLUE
3/25/25

 FIREFLY YELLOW
3/25/25

 ULTRA MARINE VIOLET
3/25/25



REASONS TO BELIEVE

Design:

Comfortable single hand or hands free carry

Durable:

Materials, Construction, everything

Performance and versatility:
Fabled Tundra-level cold-holding
Designed for on-the-go use

Easy to Use:

Quick access/draining & thoughtful interior





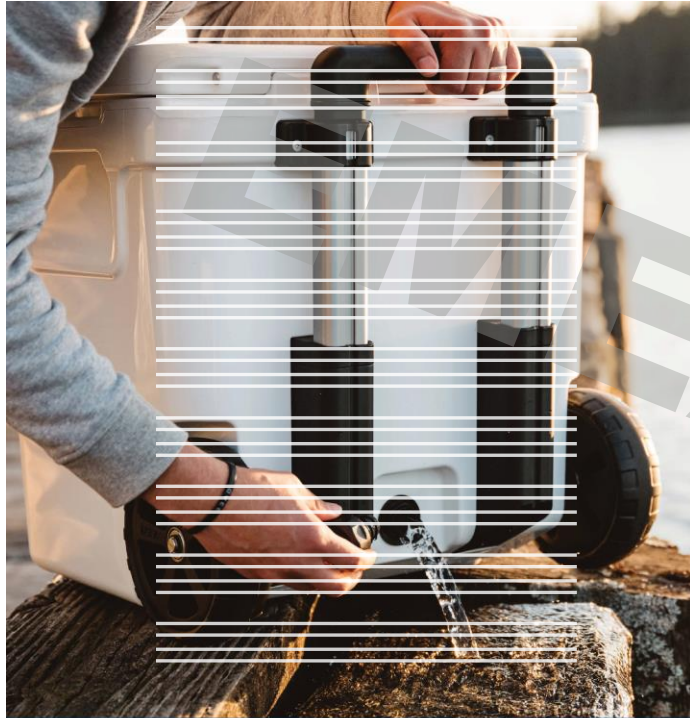

ROADIE 24

INSTORE POS – H-FRAME

*All designs shown are FPO and will be finalized at a later point



YETI
ROADIE 24 2.0. BUILT TO GO THE DISTANCE. AND AGAIN.

 NEW CONVERTIBLE SHOULDER STRAP	 QUICKLATCH	 LIPGRIP HANDLES	 BEARFOOT NON-SLIP FEET	 NEW BESTDAM
<small>SWITCH FROM SHOULDER STRAP TO HAND STRAP WITH EASE.</small>	<small>ONE FINGER DOES THE TRICK. LATCHES OPEN WITH A QUICK FLIP AND CLOSE JUST AS EASILY.</small>	<small>STAY OUT OF THE WAY AND MAKE CARRYING YOUR CATCH EASY.</small>	<small>PREVENT SLIDING TO KEEP YOUR COOLER IN PLACE.</small>	<small>LEAK-PROOF, RUGGED, AND DESIGNED FOR QUICK AND EASY DRAINING.</small>

YETI
ALL NEW ROADIE 24
BUILT TO GO THE DISTANCE. AND AGAIN.

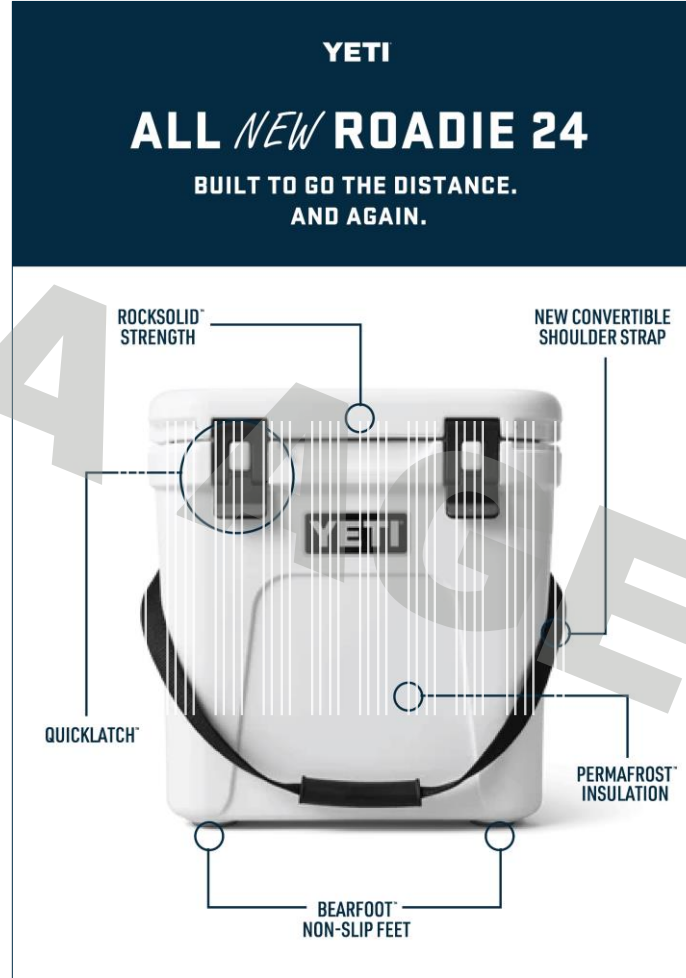

ROCKSOLID[™] STRENGTH

NEW CONVERTIBLE SHOULDER STRAP

QUICKLATCH[™]

PERMAFROST[™] INSULATION

BEARFOOT[™] NON-SLIP FEET

ROADIE 24

INSTORE POS – LAUNCH DATE 3/25

*All designs shown are FPO and will be finalized at a later point



H-FRAME

ROADIE2.0-HFRAME-ENG

ROADIE2.0-HFRAME-DE

ROADIE2.0-HFRAME-ES

ROADIE2.0-HFRAME-FR

ROADIE2.0-HFRAME-IT



CARGO AND OUTDOOR LIVING



CARGO & OUTDOOR LIVING

1H25 KEY PRIORITIES

**FOCUS ON GOBOX
AHEAD OF EXPANSION**



**INTRODUCE INNOVATION IN
THE CHAIR CATEGORY**



**EXPAND AWARENESS
FOR GEAR CRATE**





EMEA

AG

YETI

YETI CHAIRS

MODEL OVERVIEW

NEW
!



BEACH
CHAIR

280€/£250

4,5KG



TRAILHEAD CAMP
CHAIR

340€/£300

5,9KG

YETI BEACH CHAIR OPPORTUNITY

YETI'S BEACH CHAIR WILL DIFFERENTIATE WITH COMFORT AND DURABILITY IN A MARKET LITTERED WITH OPTIONS THAT LAST ONLY ONE SEASON.

WITH AN ADJUSTABLE RECLINE AND FAMILIAR YET SLEEK DESIGN, IT'S THE LAST BEACH CHAIR YOU'LL EVER BUY.



YETI BEACH CHAIR

PRODUCT DETAILS



YETI BEACH CHAIR

PRODUCT DETAILS

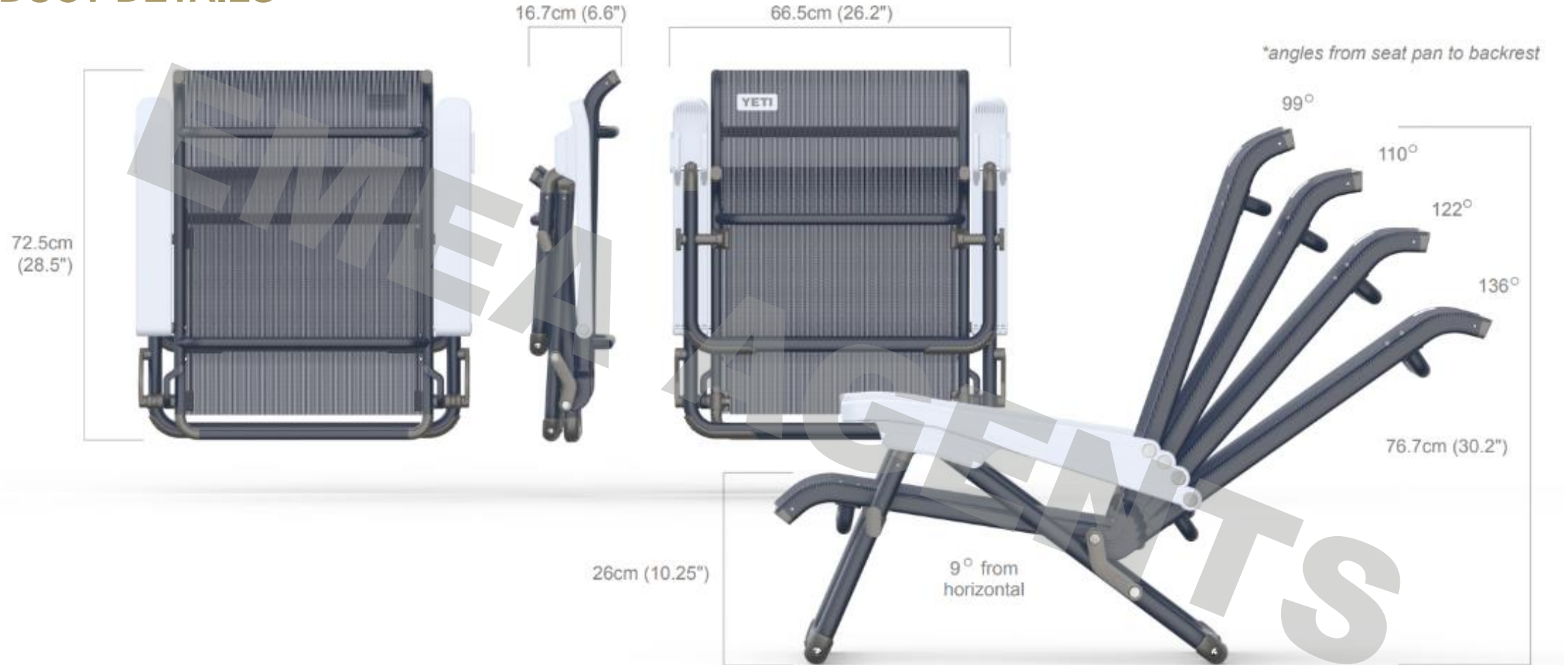

YETI BEACH CHAIR

PRODUCT OVERVIEW AND GO-TO-MARKET



D2C LAUNCH
2/18



WHOLESALE LAUNCH
2/18



280€/£250



INLINE COLORS

NAVY

SEAFOAM

KING CRAB ORANGE

CAPE TAUPE



REASONS TO BELIEVE

Design:

In order to get where it needs to go, this chair is lighter-weight than current chairs with easy methods for carrying.

Durable:

Built to be used hard season after season and stand up to the elements.

Performance and versatility:

Lightest chair built by YETI so far combining portability and comfort/
4,5kg vs 5,9kg for the Trailhead camp chair

Easy to Use, Versatile & Portable:

Ultimate nap-friendly comfort with four stages of recline



YETI BEACH CHAIR

MERCHANDISING



YETI

SOFT COOLERS

YETI



SOFT COOLERS 1H25 KEY PRIORITIES

AMPLIFY FOCUS ON
HOPPER & M-SERIES



REVAMP & EXPAND
DAYTRIP



SOFT COOLER

MODEL OVERVIEW

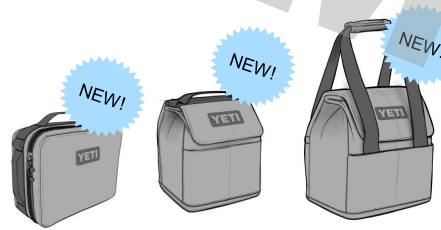

DAYTRIP

BOX | MEDIUM BAG | LARGE BAG

BOX 90€/£80
MEDIUM 90€/£80
LARGE 135€/£125



HOPPER FLIP

8 | 12 | 18

FLIP 8 230€/£200
FLIP 12 280€/£250
FLIP 18 340€/£300

HOPPER TOTE & BACKPACK

M30 | M15 | M20 | M12

M30 390€/£350
M15 340€/£300
M20 360€/£325
M12 310€/£275

DAYTRIP SOFT COOLERS

DAYTRIP OFFERS A PREMIUM LUNCH SOLUTION THAT IS EASY ACCESS, LIGHTWEIGHT & PERFECTLY COMPATIBLE WITH THE YETI ECOSYSTEM.

CONSUMERS ARE REQUESTING PRODUCT ENHANCEMENTS TO EXISTING MODELS AND SEEKING INCREASED CAPACITY FOR LARGER LUNCHES AND EXPENDED USE CASES.



DAYTRIP LUNCH BOX

DAYTRIP MEDIUM LUNCH BAG

DAYTRIP LARGE LUNCH BAG



DAYTRIP SOFT COOLERS

COMPARISON AND USAGE

DAYTRIP LUNCH BOX



ONE PERSON



DAYTRIP MEDIUM LUNCH BAG



TWO PEOPLE

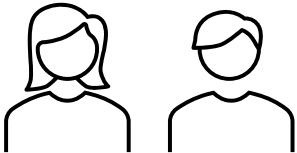

DAYTRIP LARGE LUNCH BAG



TWO PEOPLE +
/ FAMILY SNACKS

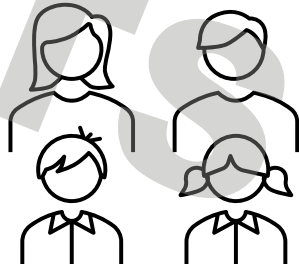

DAYTRIP SOFT COOLERS

COMPARISON AND USAGE

DAYTRIP LUNCH BOX



DAYTRIP MEDIUM LUNCH BAG

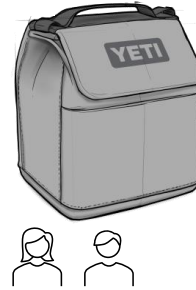

DAYTRIP LARGE LUNCH BAG



Increased insulation slightly from previous versions to improve thermal

Same quality of foam insulation on all x3 models, with some difference in thickness.

DAYTRIP SOFT COOLERS

COMPARISON AND USAGE

DAYTRIP LUNCH BOX



Capacity:
5L (increased from Daytrip 1.0 at 3L)
Packing lists:
1 large YETI Thin Ice &
+1 Large Food Container

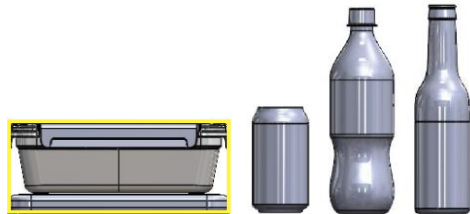

DAYTRIP MEDIUM LUNCH BAG

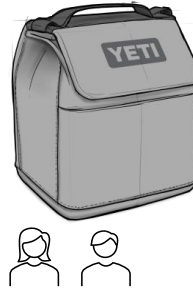

Capacity:
6.5L (inline with Daytrip 1.0)
Packing lists:
2 large YETI Thin Ice
+1 Large Food Container

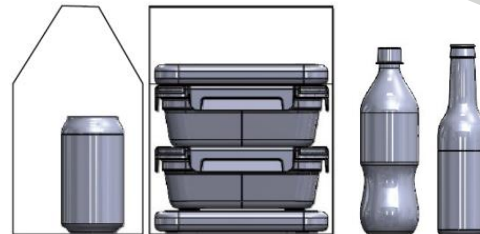

DAYTRIP LARGE LUNCH BAG



Capacity :
13.5L
Packing lists:
1 large YETI Thin Ice &
2 Large Food Container.
Wine bottle compatible

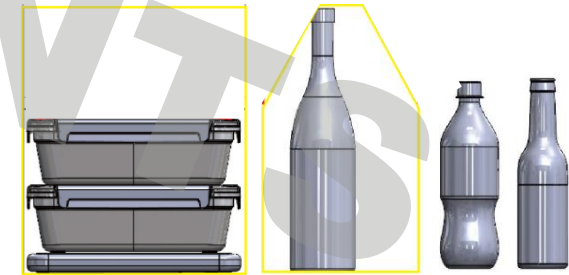

DAYTRIP LUNCH BOX

PRODUCT DETAILS

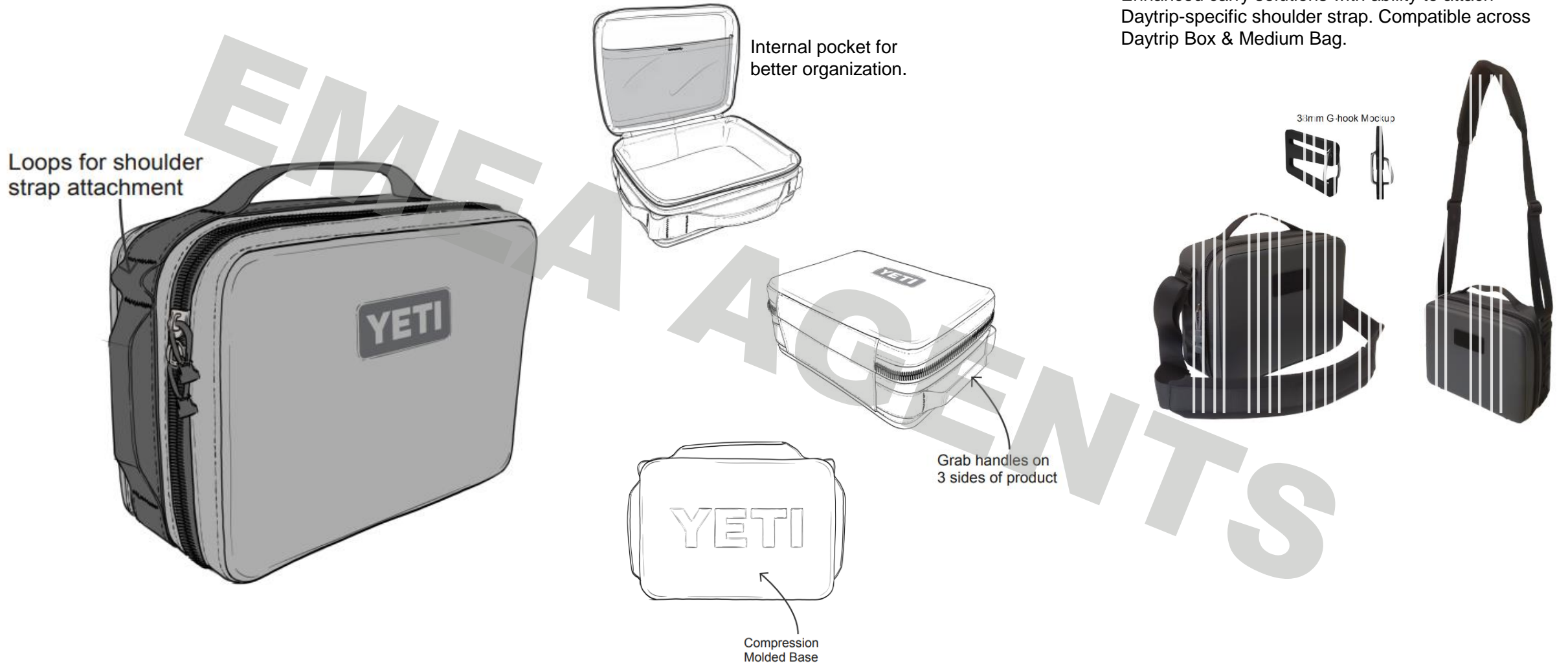

DAYTRIP MEDIUM LUNCH BAG

PRODUCT DETAILS

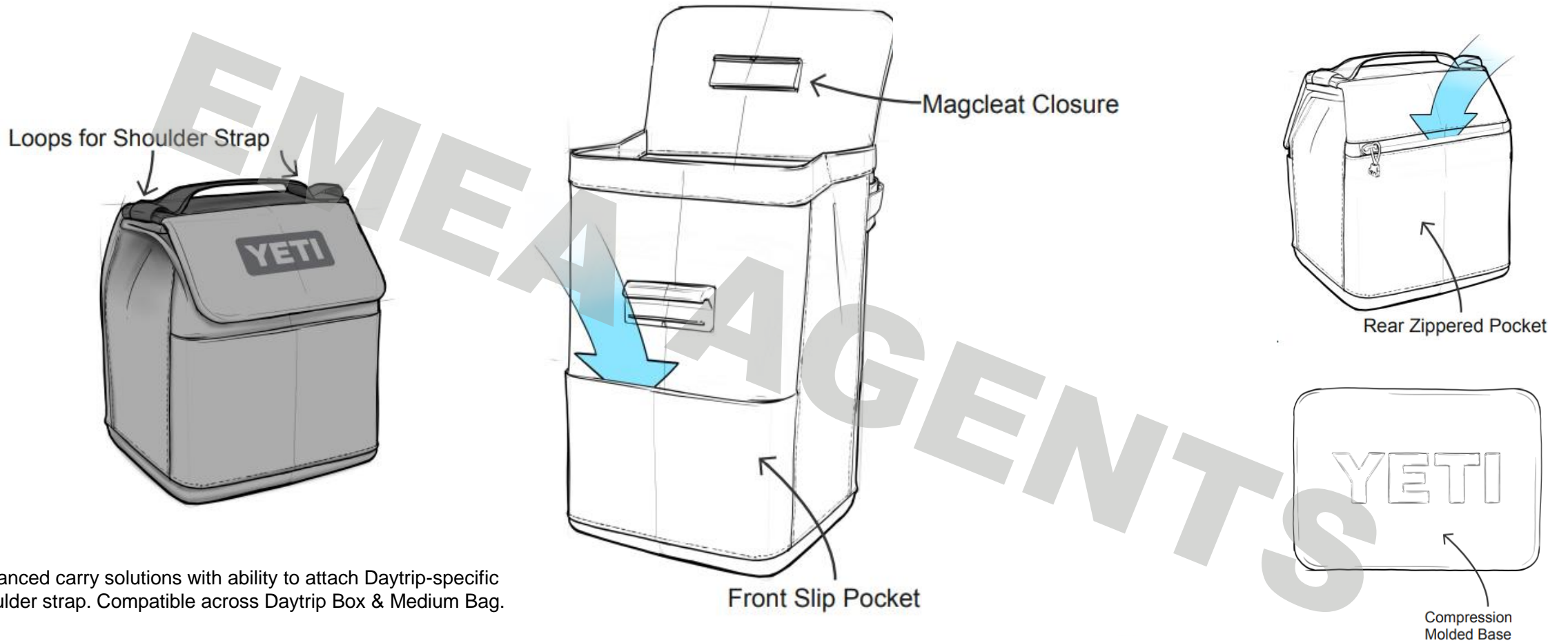

Enhanced carry solutions with ability to attach Daytrip-specific shoulder strap. Compatible across Daytrip Box & Medium Bag.

DAYTRIP LARGE LUNCH BAG

PRODUCT DETAILS

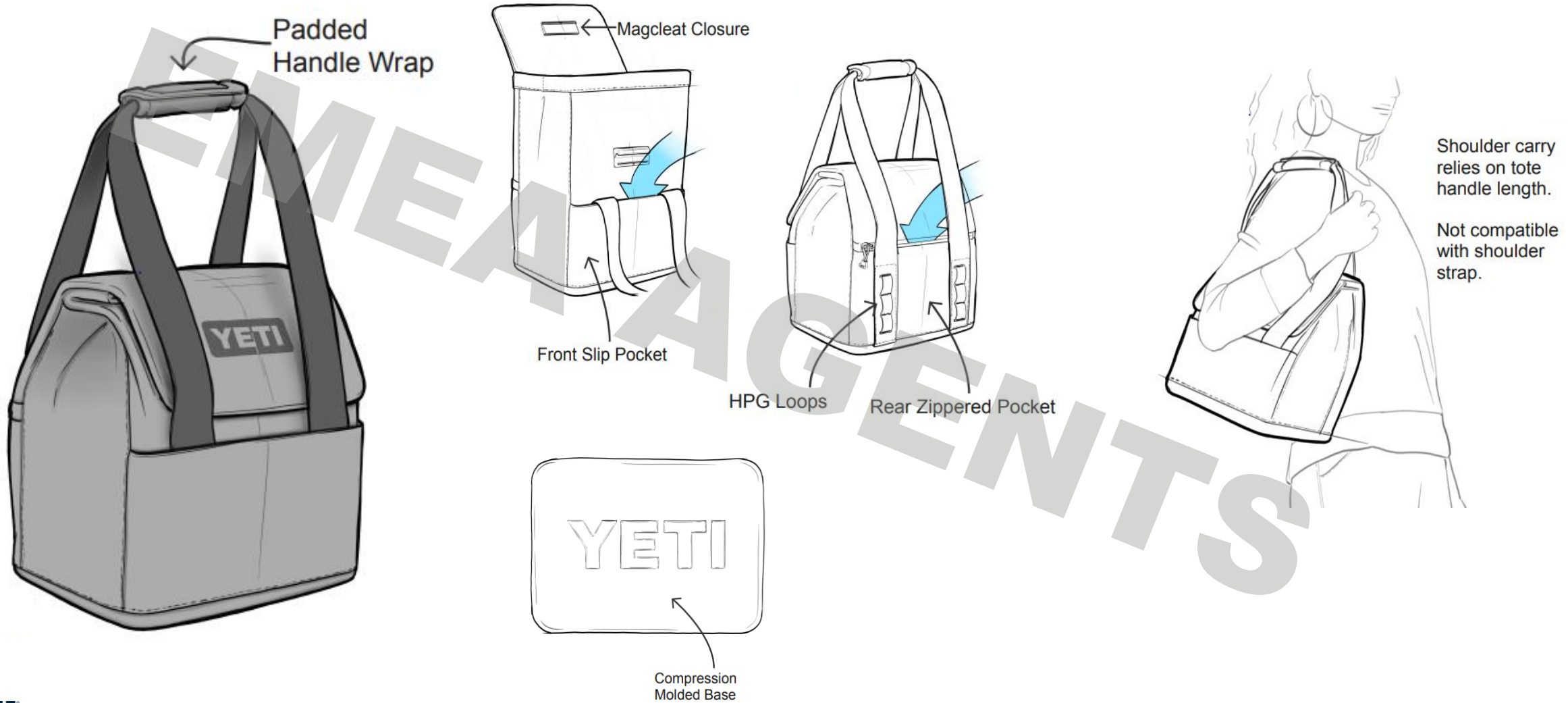

DAYTRIP 2.0

PRODUCT OVERVIEW AND GO-TO-MARKET



D2C LAUNCH

6/17



WHOLESALE LAUNCH

6/17



Box
90€/£80



Lunch Bag M
90€/£80



Lunch Bag L
135€/£125

INLINE COLORS



BLACK



OLIVE



RESCUE RED
(long range)

END OF LIFE DAYTRIP 1.0

INLINE COLORS



BLACK



NAVY



OLIVE

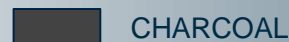

CHARCOAL

SEASONAL COLORS,
FIREFLY YELLOW
2/11/25

REASONS TO BELIEVE

Design:

Product updates & size expansion to enhance consumer experience and compatibility with YETI Ecosystem. Added features including shoulder strap for carrying optionality and added pockets for better organization.

Durable:

Premium materials & construction.

Performance and versatility:

Lightweight. ColdCell insulation, 1 day worth of ice retention.

Easy to Use, Versatile & Portable:

Designed for on-the-go use
Easy access, leak resistant closure. Compatible with removable shoulder strap for carry optionality.



DAYTRIP 2.0

ACCESSORIES



D2C LAUNCH
6/17



WHOLESALE LAUNCH
6/17



Box
90€/£80



Lunch Bag M
90€/£80



Lunch Bag L
135€/£125

Compatible with Lunch
Box and Lunch Bag



Shoulder Strap
20€/£15

DAYTRIP 2.0

INSTORE POS – H-FRAME & STRUTCARD

*All designs shown are FPO and will be finalized at a later point



YETI
ALL NEW DAYTRIP SOFT COOLERS.

ALL COMPATIBLE WITH
YETI
LARGE THIN ICE

DAYTRIP LUNCHBOX
1 LARGE YETI THIN ICE
1 LARGE FOOD CONTAINER

DAYTRIP MEDIUM LUNCHBAG
1 LARGE YETI THIN ICE
2 LARGE FOOD CONTAINERS

DAYTRIP LARGE LUNCHBAG
1 LARGE YETI THIN ICE
2 LARGE FOOD CONTAINERS
FAMILY SNACKS
WINE BOTTLE COMPATIBLE

INTERNAL STORAGE
GRAB HANDLES

MAGCLEAT CLOSURE
SLIP POCKET
ZIPPERED POCKET

MAGCLEAT CLOSURE
SLIP POCKET
ZIPPERED POCKET
HPG LOOPS



DAYTRIP 2.0

INSTORE POS – LAUNCH DATE 6/17

*All designs shown are FPO and will be finalized at a later point

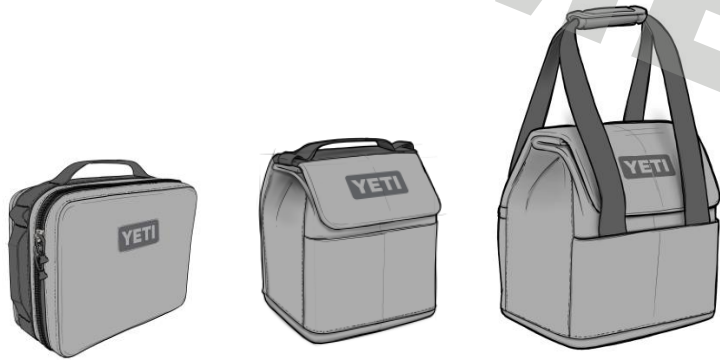

STRUT CARD

DTRIP2.0-SCARD-ENG

DTRIP2.0-SCARD-DE

DTRIP2.0-SCARD-ES

DTRIP2.0-SCARD-FR

DTRIP2.0-SCARD-IT



H-FRAME

DTRIP2.0-HFRAME-ENG

DTRIP2.0-HFRAME-DE

DTRIP2.0-HFRAME-ES

DTRIP2.0-HFRAME-FR

DTRIP2.0-HFRAME-IT



BAGS

BAGS OVERVIEW

PROTECTION AGAINST ELEMENTS



SIDEKICK | PANGA |
"BACKROADS"

NEW!



EASY ACCESS AND MULTI-PURPOSE



CAMINO | RANCHERO BAGS

NEW!



ORGANIZATION UNCOMPROMISED



CROSSROADS | PACKING
CUBES



BAGS OVERVIEW

INTRODUCING A NEW YETI BAG FRANCHISE THAT MEETS THE DEMANDS OF OUTDOOR ADVENTURERS WHO REQUIRE DURABILITY, EASY ACCESS & ULTIMATE AGILITY.

EASY ACCESS
AND MULTI-PURPOSE



RANCHERO BAGS
RIP ZIP BRIEFCASE
CAMINO



RANCHERO 22

PRODUCT OVERVIEW



RACHERO 27

PRODUCT OVERVIEW

Loop patch with reflective logo.

Ranchero Opening.

TuffSkin exterior fabric.

Coated zippers for Durability and water resistance.



Dedicated laptop zipper compartment. (see side view)

Easy access zippered hydration storage pockets. (x2 symmetrical pockets on 25L & 35L, x1 pocket on 15L)

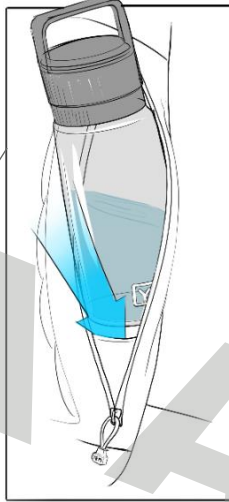

Top & side grab handles



Molded back panel with large logo hit.

5PM Coated fabric on bottom-base for durability and weather-proofness.

Internal organization.



On face: Zip secure stretch woven pockets. Lower water bottle pockets
On back: Stretch woven zippered pocket.

Side View.



- 1 Laptop compartment with DWR zipper
- 2 Side access to water bottles

RIP ZIP 4-WAY BRIEFCASE

PRODUCT OVERVIEW

****Still Working****

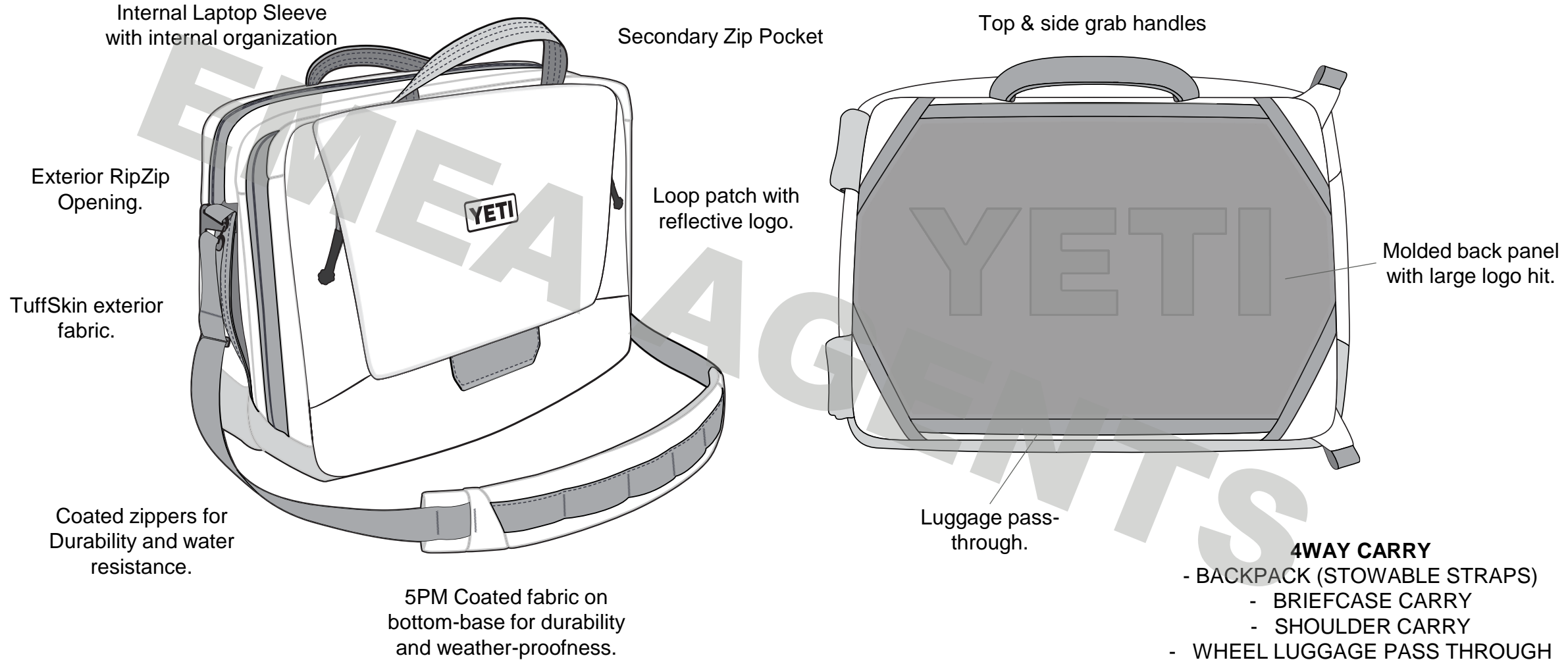

YETI

RANCHERO AND RIP ZIP

PRODUCT OVERVIEW AND GO-TO-MARKET



D2C LAUNCH

2/18



WHOLESALE LAUNCH

2/18

INLINE COLORS



BLACK



DARK CAPE
TAUPE



OLIVE



RANCHERO
22
250€/£225



RANCHERO
27
310€/£275



4Way Brief
290€/£250
****Still
Working****

- **COMFORT,**
- **ACCESSIBILITY,**
- **DURABILITY,**
- **WEATHER RESISTANCE.**

REASONS TO BELIEVE

Comfort:

Molded dual-foam body panel with lumbar support.
Shoulder straps and chestie for additional comfort and security.

Accessibility:

Rip Zip main opening with additional side-zip secure water bottle pockets.

Durable:

Legendary YETI tough materials & construction.

Water Resistant and versatile

Weatherproof main fabric and coated zippers.
Organization fit for the office with extended uses for outdoor excursions



“BACKROADS”

PRODUCT OVERVIEW

Quick access secure zip pocket.

Ultimate weather protection with TPU fabric, welded seams & PU coated water resistant zippers.

Hitchpoint grid for attachment of accessories.



Easy access zippered hydration storage pockets. (x2 symmetrical pockets on 25L & 35L, x1 pocket on 15L)

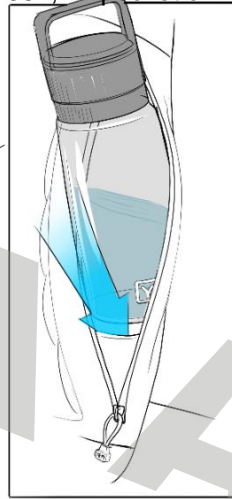

Top & side grab handles



Removable waist strap for added support & comfort.

Internal organization.

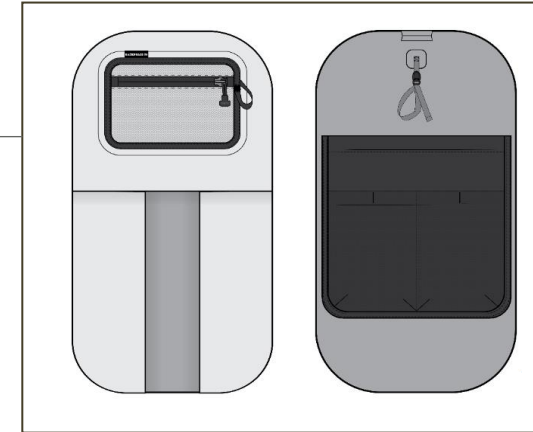

On face: Secure stretch mesh pocket. On back: Water hydration compatible with hanger & pass-thru. Hydration reservoir compartment duals as laptop pocket. Two open stretch pockets.

Ergonomic & breathable back panel.

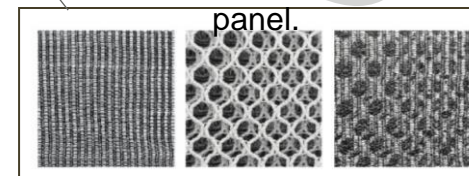

“BACKROADS”

PRODUCT OVERVIEW AND GO-TO-MARKET



D2C LAUNCH

5/20



WHOLESALE LAUNCH

6/10



15 L
200€/£175



25 L
250€/£225



35L
310€/£275

INLINE COLORS



BLACK



OLIVE

- **DURABILITY,**
- **WEATHER RESISTANCE,**
- **ULTIMATE AGILITY**



BRAND INSIGHT

Our consumers in all their pursuits lead active lifestyles ... in the outdoors. They perform. Their gear needs to perform. Outdoor adventures challenge the strongest and their gear. Mother Nature is beautiful but pulls no punches. Backroads will balance the essential outdoor, active needs of agility, weather resistance, durability and comfort.

CONSUMER INSIGHT

Among YETI owners, YETI Bags owners have a higher propensity for being outdoor enthusiasts and more likely interested in camping, hiking, scouting, riding and snow pursuits.

We have anglers on water-born adventures and every day active and travelers who all enjoy a slice of the YETI dream. The outdoor adventurers are waiting for their turn. Panga is a little too burly and Crossroads not enough umph. Backroads is the sweet spot for weather resistance, high durability, and agility.

REASONS TO BELIEVE

Weatherproof:

Protection from the elements with TPU fabric, welded construction & weather-resistant zip closure.

Agility:

Ergonomic & comfortable fit with breathable back panel and removable chest & waist strap.

Durable:

Legendary YETI tough materials & construction.

Versatile

Pursuit organization with dual-purpose hydration storage compartments, water reservoir compatibility & size range.



COLOURS

YETI

YETI COLORS

01

Deliver Core options

Align with commercial relevancy and business needs across all product categories.

02

Inspiring Color executions

Cross category with deep story telling. Will reach all channels and have broad assortment offering.

03

Segmented Color Drops

Measured drop of color for key commercial periods, or brand moments that connect to core communities. Limited assortments with shorter lifecycle.

CREATIVE DIRECTION

1H 2025 COLOR

Vibrant luminosity

Reflection of light

Flash of color

Hyper-real brightness

Bright + light

Natural wonder

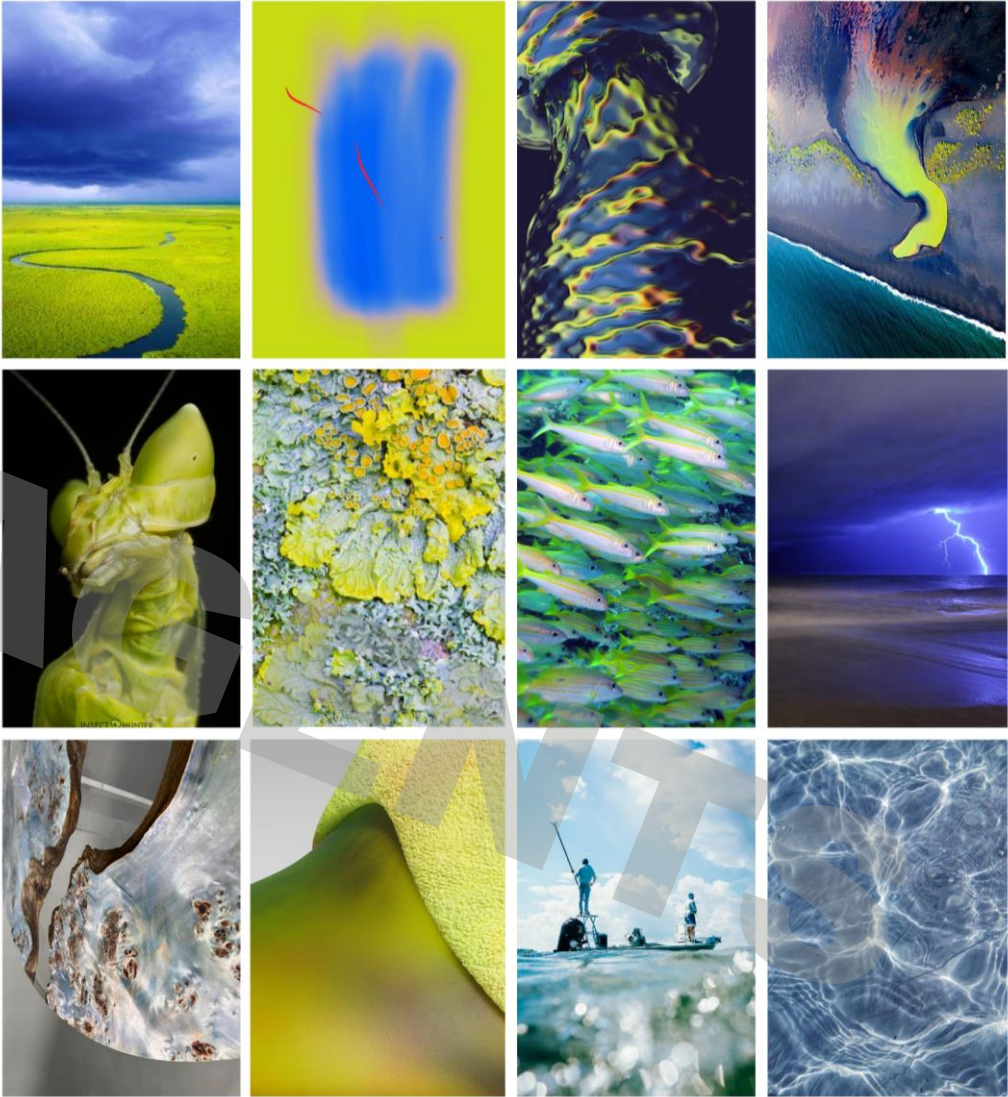

COLOR PALETTE

1H 2025 COLOR

FIREFLY YELLOW



A vertical color swatch for Firefly Yellow. The top portion is a bright yellow, and the bottom portion is a darker olive green. A calendar icon is centered in the bottom portion, displaying the date 2/11.

BIG SKY BLUE



A vertical color swatch for Big Sky Blue. The top portion is a light blue, and the bottom portion is a darker blue. A calendar icon is centered in the bottom portion, displaying the date 2/11.

ULTRAMARINE VIOLET

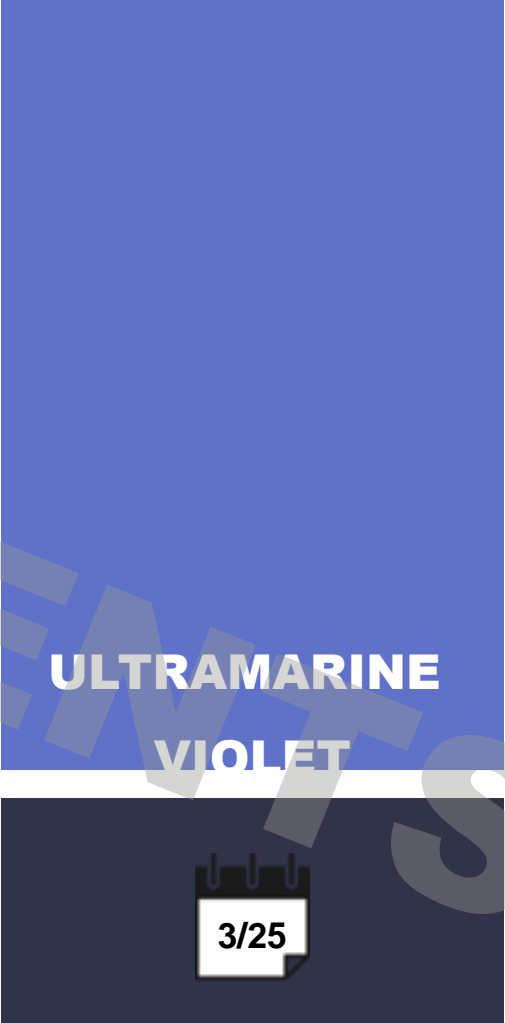

A vertical color swatch for Ultramarine Violet. The top portion is a dark blue, and the bottom portion is a very dark blue. A calendar icon is centered in the bottom portion, displaying the date 3/25.

ACTIVE SEASONAL COLORS BY CATEGORY

LAUNCH TIMING

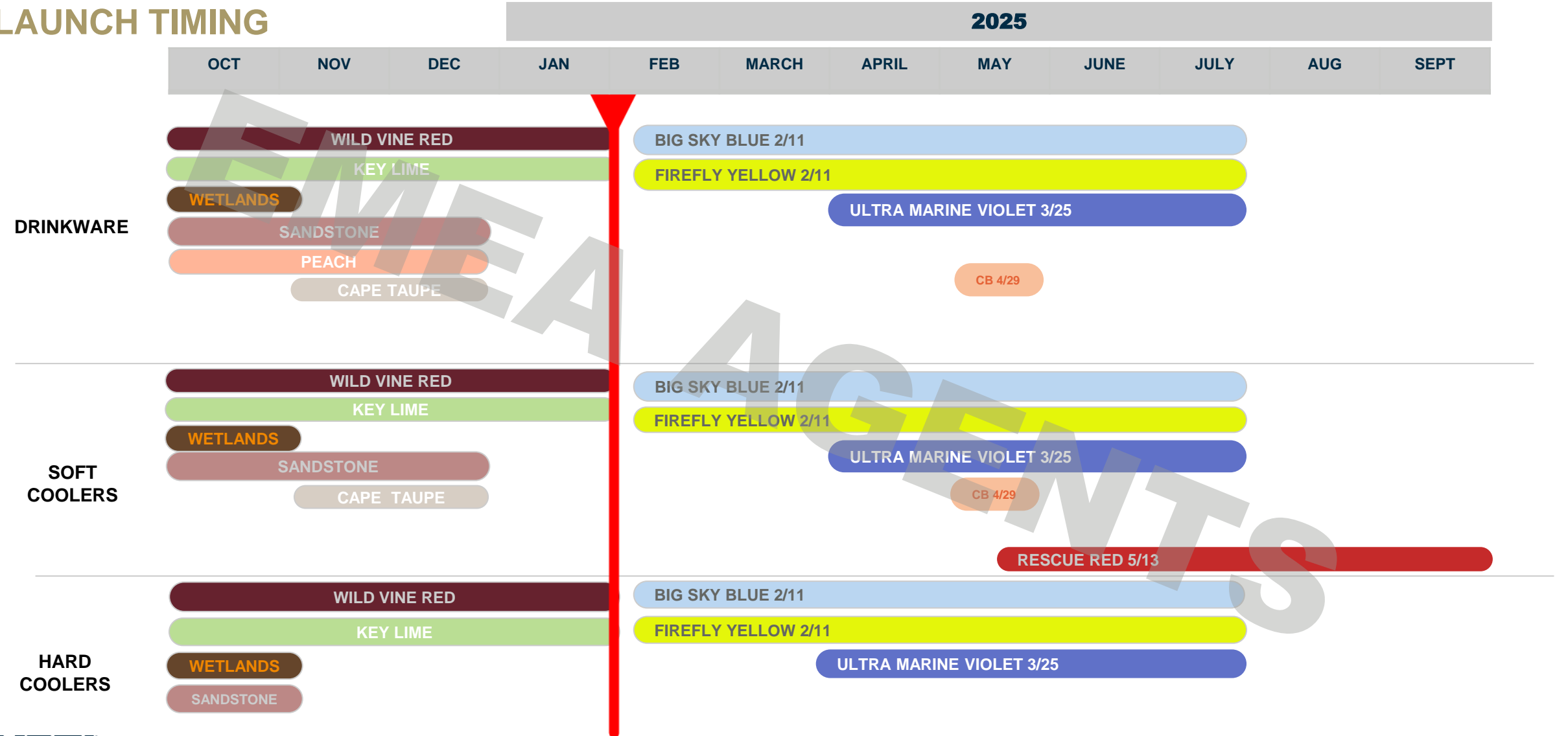

FIREFLY YELLOW



Color key words – hyper-bright, vibrant, energizing, engaging, electric.

FIREFLY YELLOW PRODUCT RENDERINGS



YETI

CONFIDENTIAL 127

This information is non-public, confidential, and proprietary. Sharing or posting by anyone in your organization in any way violates the terms of your dealer agreement.

COLOR COMPARISON – GREEN/YELLOW

FIREFLY YELLOW

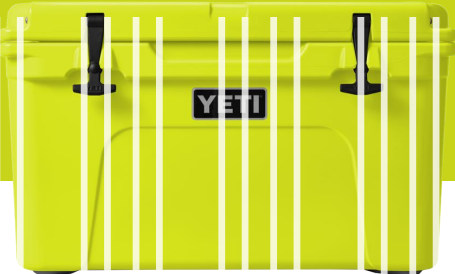

1H25

KEY LIME



2H24

FIREFLY YELLOW ASSORTMENT LIST

2/11

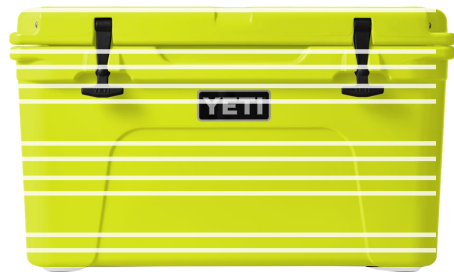

NOTE: Renders are not representative of final / all products

YETI

DRINKWARE

- Rambler 8 oz Stackable Tumbler
- Rambler 16 oz Stackable Cup
- Rambler 20 oz Stackable Cup
- Rambler 30 oz Stackable Cup
- Rambler 10 oz Tumbler
- Rambler 20 oz Tumbler
- Rambler 20 oz Travel Mug
- Rambler 30 oz Travel Mug
- Rambler 25 oz Mug w/ Straw
- Rambler 35 oz Mug w/ Straw
- Rambler 42 oz Mug w/ Straw

DRINKWARE ACCESSORIES

- MagSlider Pack
- Rambler Bottle Straw Cap
- Yonder Bottle Straw Cap

BOTTLES

- Rambler 12 oz Kids Bottle
- Rambler 12 oz Bottle w/ HotShot 2.0
- Rambler 16 oz Bottle w/ HotShot 2.0
- Rambler 18 oz Bottle w/ Chug
- Rambler 18 oz Bottle w/ Colored Straw
- Rambler 26 oz Bottle w/ Chug
- Rambler 26 oz Bottle w/ Straw
- Rambler 36 oz Bottle w/ ChuG
- Rambler 46 oz Bottle w/ Chug
- Rambler 64 oz Bottle w/ Chug
- Rambler ½ Gallon Jug 2.0
- Rambler 1 Gallon Jug 2.0
- Yonder .75 L Bottle w/ Colored Straw
- Yonder 1 L Bottle

BOTTLE ACCESSORIES

- Bottle Sling Small
- Bottle Sling Large

FOOD

- Food Jar 8oz
- Food Jar 16oz
- Food Jar 24oz
- Food Jar 40oz

BAGS

- Camino 20
- Camino 35
- Sidekick Dry 1 L
- Sidekick Dry 3 L
- Sidekick Dry 6 L
- Side Click Waistbelt

- Panga 28 Backpack
- Panga 50

- Packing Cubes – Crossroads S
- Packing Cubes – Crossroads M
- Packing Cubes – Crossroads L

HARD COOLERS

- Roadie 15
- Roadie 24 2.0
- Roadie 32
- Roadie 48
- Roadie 60
- Tundra 45
- Tundra Haul

SOFT COOLERS

- Daytrip Lunch Bag
- Daytrip Lunch Box
- Hopper Flip 8
- Hopper Flip 12
- Hopper Flip 18
- Hopper M12 Backpack
- Hopper M20 Backpack

EQUIPMENT

- GoBox 15
- GoBox 30
- GoBox 60
- LoadOut Bucket
- LoadOut Gear Crate
- Boomer 4
- Boomer 8

FIREFLY YELLOW

MERCHANDISING



FIREFLY YELLOW

INSTORE POS – LAUNCH DATE 2/4

*All designs shown are FPO and will be finalized at a later point

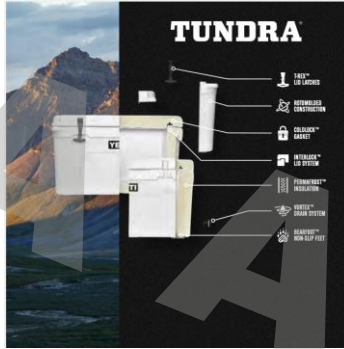
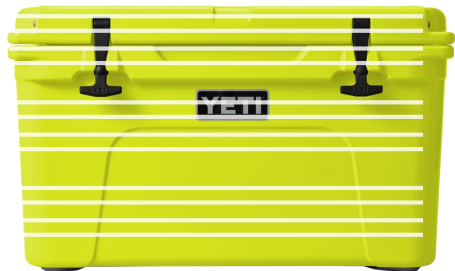

STRUT CARD

FY-SCARD-ENG

FY-SCARD-DE



CUBE

BSB/FY-CUBE-ENG

BSB/FY-CUBE-DE

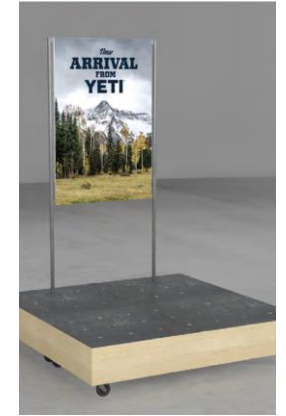

H-FRAME

BSB/FY-FRAME-ENG

BSB/FY-FRAME-DE



BIG SKY BLUE



Color key words – light, fresh, calm and tranquil, classic, heritage inspired.

BIG SKY BLUE PRODUCT RENDERINGS



COLOR COMPARISON – GREEN/YELLOW

BIG SKY BLUE

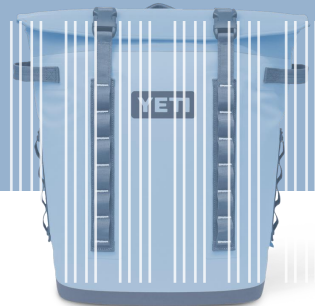
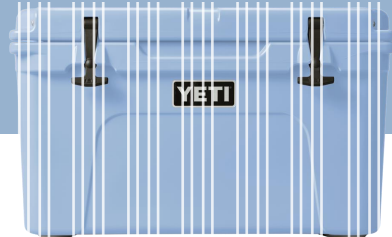

1H25

BIG WAVE



1H24

COSMIC



2H23



BIG SKY BLUE ASSORTMENT LIST

2/11

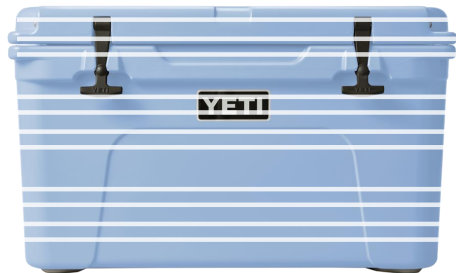

NOTE: Renders are not
representative of final / all products

DRINKWARE

Rambler 10 oz Mug
Rambler 10 oz Wine
Rambler 14 oz Mug
Rambler 4 oz Stackable Cups
Rambler 6 oz Stackable Mugs
Rambler 8 oz Stackable Tumbler
Rambler 16 oz Stackable Cup
Rambler 20 oz Stackable Cup
Rambler 10 oz Tumbler
Rambler 20 oz Tumbler
Rambler 20 oz Travel Mug
Rambler 25 oz Mug w/ Straw
Rambler 35 oz Mug w/ Straw
Rambler 42 oz Mug w/ Straw

DRINKWARE ACCESSORIES

MagSlider Pack

BOTTLES

Rambler 12 oz Kids Bottle
Rambler 12 oz Bottle w/ HotShot 2.0
Rambler 16 oz Bottle w/ HotShot 2.0
Rambler 18 oz Bottle w/ Chug
Rambler 18 oz Bottle w/ Colored
Straw
Rambler 26 oz Bottle w/ Chug
Rambler 26 oz Bottle w/ Straw
Rambler 36 oz Bottle w/ ChuG

BOTTLES ACCESSORIES

Rambler Bottle Straw Cap

FOOD

Food Jar 8 oz
Food Jar 16 oz
Food Jar 24 oz

TABLEWARE

Rambler Cocktail Shaker
Rambler Beverage Bucket
Rambler Wine Chiller

BAGS

Sidekick Dry 1 L
Sidekick Dry 3 L

HARD COOLERS

Roadie 15
Roadie 24 2.0
Roadie 32
Tundra 35
Tundra 45
Tundra Haul

SOFT COOLERS

Hopper Flip 12
Hopper M12 Backpack
Hopper M20 Backpack
Hopper M15 Tote
Hopper M30 Tote

EQUIPMENT

Lowlands Blanket

YETI

BIG SKY BLUE

INSTORE POS – LAUNCH DATE 2/4

*All designs shown are FPO and will be finalized at a later point

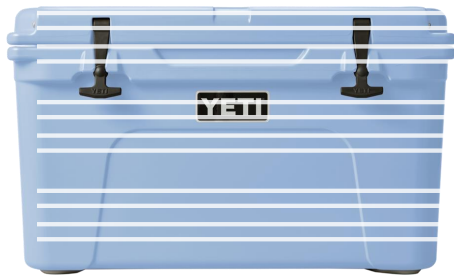

NOTE: Renders are not representative of final / all products

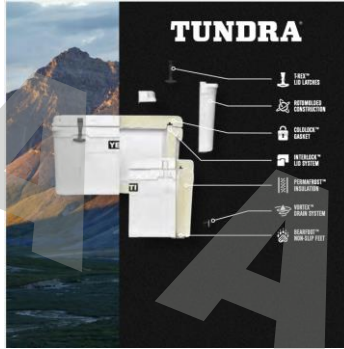

STRUT CARD

BSB-SCARD-ENG

BSB-SCARD-DE



CUBE

BSB/FY-CUBE-ENG

BSB/FY-CUBE-DE

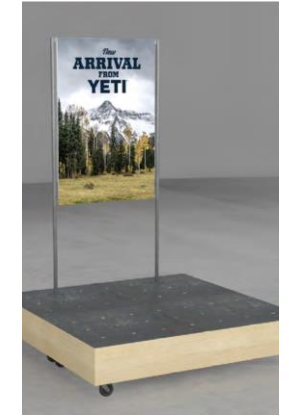

H-FRAME

BSB/FY-FRAME-ENG

BSB/FY-FRAME-DE



BIG SKY BLUE

MERCHANDISING



This information is non-public, confidential, and proprietary. Sharing or posting by anyone in your organization in any way violates the terms of your dealer agreement.

BIG SKY BLUE & FIREFLY YELLOW

MIXED MERCHANDISING



ULTRA MARINE VIOLET PRODUCT RENDERINGS

3/25



Color key words – dynamic, high-contrast, balanced, intriguing, super-natural.

YETI

This information is non-public, confidential, and proprietary. Sharing or posting by anyone in your organization in any way violates the terms of your dealer agreement.

CONFIDENTIAL 139

COLOR COMPARISON – GREEN/YELLOW

ULTRAMARINE
VIOLET



1H25

OFFSHORE



2H22



ULTRA MARINE VIOLET ASSORTMENT LIST

3/25



DRINKWARE

Rambler 10 oz Mug
Rambler 10 oz Wine
Rambler 14 oz Mug
Rambler 4 oz Stackable Cups
Rambler 8 oz Stackable Tumbler
Rambler 16 oz Stackable Cup
Rambler 20 oz Stackable Cup
Rambler 10 oz Tumbler
Rambler 20 oz Tumbler
Rambler 20 oz Travel Mug
Rambler 25 oz Mug w/ Straw
Rambler 35 oz Mug w/ Straw
Rambler 42 oz Mug w/ Straw

DRINKWARE ACCESSORIES

MagSlider Pack



NOTE: Renders are not representative of final / all products

BOTTLES

Rambler 12 oz Kids Bottle
Rambler 12 oz Bottle w/ HotShot 2.0
Rambler 16 oz Bottle w/ HotShot 2.0
Rambler 18 oz Bottle w/ Colored Straw
Rambler 26 oz Bottle w/ Straw
Rambler 36 oz Bottle w/ Chug

BOTTLES ACCESSORIES

Rambler Bottle Straw Cap

TABLEWARE

Rambler Cocktail Shaker
Rambler 34 oz French Press
Rambler 64 oz Pitcher
Rambler Beverage Bucket
Rambler Wine Chiller
Shot Glasses + Carry Case

BAGS

Camino 20
Camino 35
Sidekick Dry 1 L
Sidekick Dry 3 L

Crossroads 27 L Backpack

HARD COOLERS

Roadie 15
Roadie 24 2.0
Tundra 45

SOFT COOLERS

Hopper Flip 12
Hopper M12 Backpack
Hopper M20 Backpack
Hopper M15 Tote
Hopper M30 Tote

YETI

ULTRA MARINE VIOLET

INSTORE POS – LAUNCH DATE 3/25

*All designs shown are FPO and will be finalized at a later point

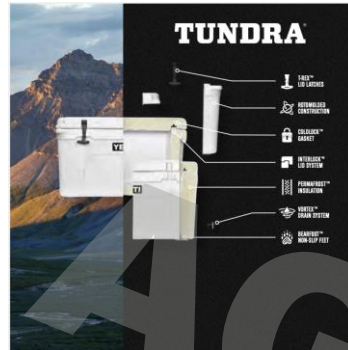

STRUT CARD

UV-SCARD-ENG

UV-SCARD-DE

H-FRAME

UV-FRAME-ENG

UV-FRAME-DE

NOTE: Renders are not representative of final / all products

YETI

ULTRAMARINE VIOLET

MERCHANDISING



1H 25

SEASONAL OVERVIEW

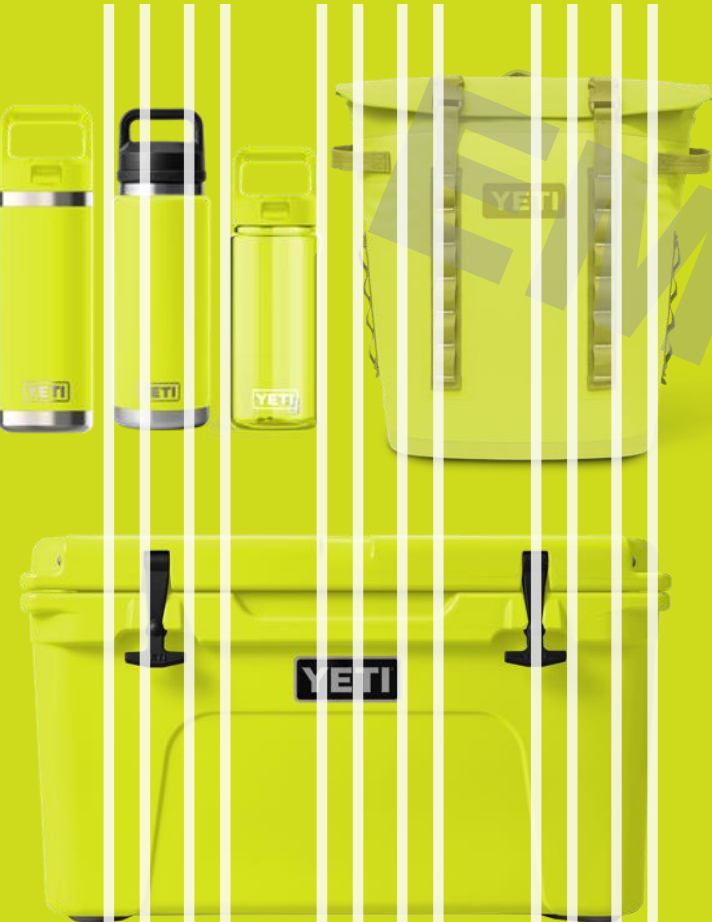

Hyper-bright, vibrant, energizing,
engaging, electric.

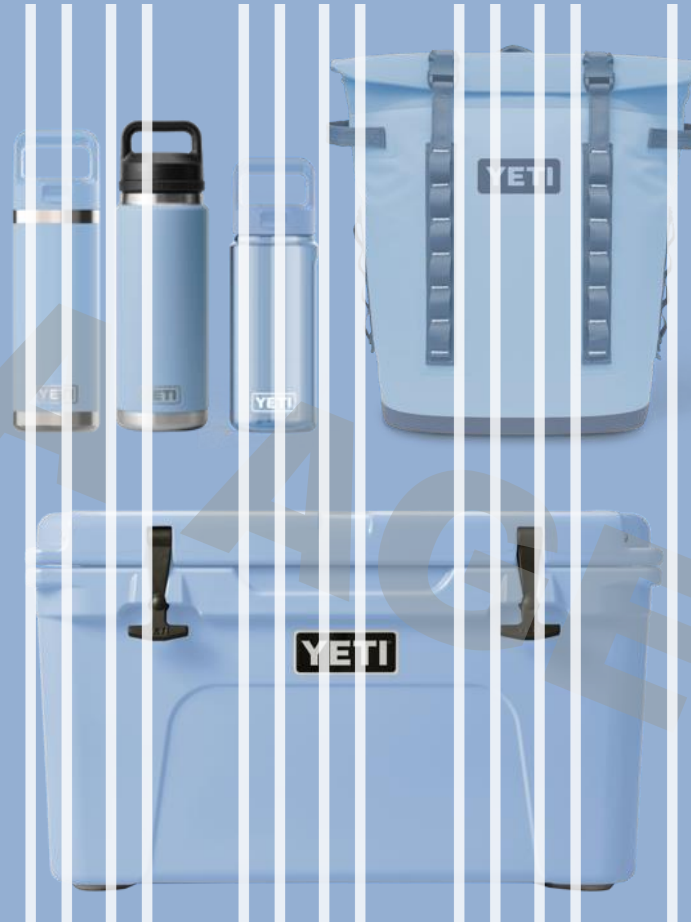

Light, fresh, calm and tranquil, classic,
heritage inspired.

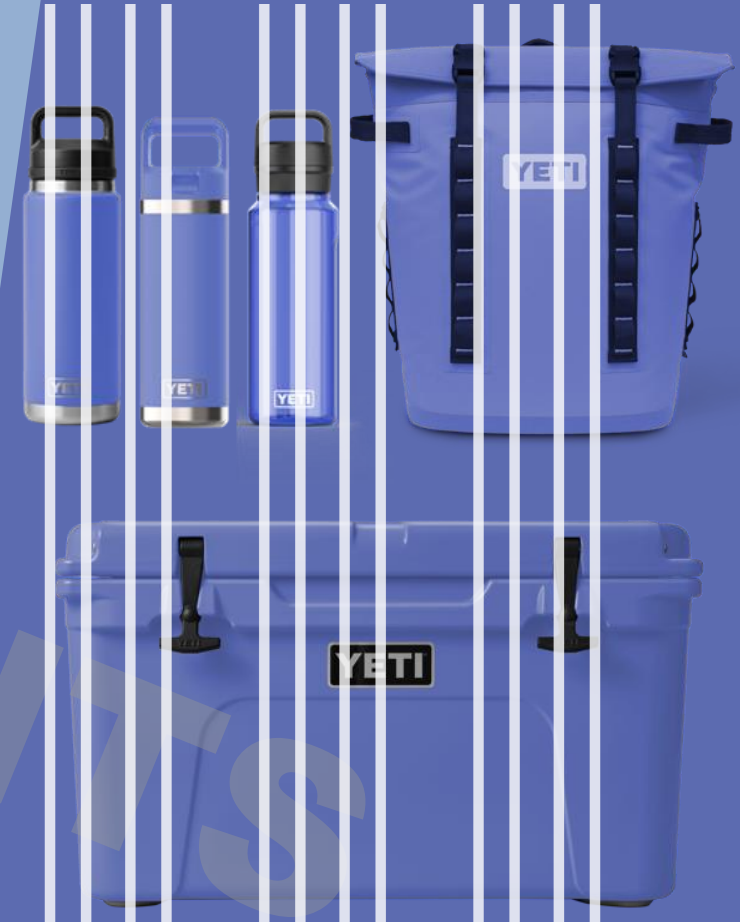

Dynamic, high-contrast, balanced,
intriguing, super-natural.

RESCUE RED PRODUCT RENDERINGS

5/13



YETI

NOTE: RENDERERS ARE NOT REPRESENTATIVE OF FINAL / ALL PRODUCTS

CONFIDENTIAL 145

This information is non-public, confidential, and proprietary. Sharing or posting by anyone in your organization in any way violates the terms of your dealer agreement.

RESCUE RED ASSORTMENT LIST

5/13



BAGS

Camino 20
Camino 35

Sidekick Dry 1 L
Sidekick Dry 3 L

Crossroads 22 L Backpack
Crossroads 27 L Backpack



SOFT GOODS

Daytrip Med Lunch Bag 2.0
Daytrip Large Lunch Bag 2.0
Daytrip Med Lunch Box 2.0

Hopper Flip 8
Hopper Flip 12
Hopper Flip 18

Hopper M20 Backpack

EQUIPMENT

GoBox 15
GoBox 30
GoBox 60

Boomer 4
Boomer 8

NOTE: Renders are not
representative of final / all products

YETI

COLOR BLOCK ASSORTMENT LIST



BAGS

- Camino 20
- Camino 35
- Sidekick Dry 1 L
- Sidekick Dry 3 L

SOFT COOLERS

- Hopper M12 Backpack
- Hopper M20 Backpack



NOTE: Renders are not
representative of final / all products









Color key words – bright + light, fresh energy, optimistic, flash of color.

PRODUCT ROADMAP

1H 2025

YETI

2025 ROADMAP

	JANUARY	FEBRUARY	MARCH	APRIL	MAY	JUNE
DRINKWARE & FOODWARE	 <p>FOOD JARS – 1/14</p>	 <p>POUR OVER & JUG 2.0 – 2/4 HOTSHOT 2.0 – 2/25</p>	 <p>FOOD BOWL – 3/19</p>			 <p>SPORTJUGS – 6/10</p>
HARD COOLERS			 <p>ROADIE 24 2.0 – 3/27</p>			
SOFT COOLERS & BAGS		 <p>RIP ZIP – 2/18</p>			 <p>BACKROADS – 5/20</p>	 <p>LUNCH BAG & BOX 2.0 – 6/17</p>
CARGO & OUTDOOR LIVING		 <p>BEACH CHAIR – 2/25</p>				
COLORS		<p>FIREFLY – 2/11</p> <p>BIG SKY BLUE – 2/11</p>		<p>ULTRA MARINE VIOLET – 3/25</p> <p>COLORBLOCK – 4/29</p>	<p>RESCUE RED SOFTG. – 5/13</p>	



OMNICHANNEL

DTC LAUNCH

This information is non-public, confidential, and proprietary. Sharing or posting by anyone in your organization in any way violates the terms of your dealer agreement.

EMERGENCY AGENTS
THANK YOU

